

ECOPAN[®]

MODULAR RADIANT PANELS



TECHNICAL MANUAL

INDEX

1 PRODUCT DESCRIPTION

1.1 Models, dimensions, weights, water contents	page 4
1.2 Construction	page 6
1.3 Production, modularity	page 6
1.4 Suspension brackets	page 6
1.5 Headers	page 6
1.6 Painting	page 6
1.7 Insulation	page 6
1.8 Operating temperature	page 6
1.9 Operating pressure	page 6
1.10 Special versions, accessories	page 6
1.11 Components of the ECOPAN radiant panel	page 8

2 DESIGN DATA

2.1 Guidelines for a correct choice	page 9
2.2 Active length	page 9
2.3 Thermal emission	page 9
2.4 Corrective coefficients for high installation heights	page 14
2.5 Corrective coefficient for inclined panels	page 14
2.6 Distance between radiant panels	page 14
2.7 Minimum height of installation	page 14
2.8 Arrangement of ceiling mounted panels	page 15
2.9 Examples of calculation of radiant panels	page 16
2.10 Effects on luminosity originating from the covering	page 17
2.11 Use in cooling systems	page 17
2.12 Diagrams of system balancing and power supply	page 18
2.13 Flow rate and speed of water in the panels	page 19
2.14 Pressure drops of panel pipes	page 19
2.15 Pressure drops of headers	page 20
2.16 Calculation of pressure drop of a panel	page 21
2.17 Static pressure and flow rate of the electric pump	page 22
2.18 Adjustment	page 23
2.19 Methods of installation and dilation	page 24
2.20 Examples of systems of fastening to roof	page 25
2.21 Packaging	page 26
2.22 Assembly	page 26
2.23 Conclusions	page 27

3 ACCESSORIES

page 28

4 CERTIFICATIONS

4.1 ECOPAN radiant panel	page 30
4.2 Insulating panel	page 30

5 TECHNICAL SPECIFICATIONS

page 31

ECOPAN® is a registered trademark.

ECOPAN® modular radiant panels are patented.

The technical, constructional and dimensional data are not binding and may be modified with no advance notice.

This manual may not be reproduced, wholly or in part, without written authorization in advance from Ecopan srl.

© Ecopan srl 2004

The new European standard EN 14037 defines how to obtain emissions which can be used to compare the various ceiling mounted radiant panels available on the market.

To make it easier to use this product, we feel it is helpful to provide a manual that contains all necessary technical data.



ECOPAN®

MODULAR RADIANT PANELS

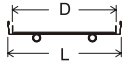
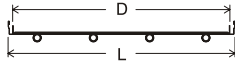
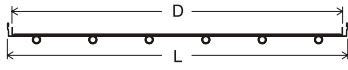
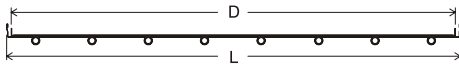
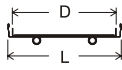
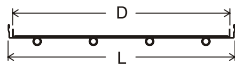
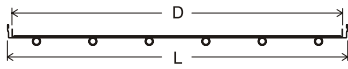
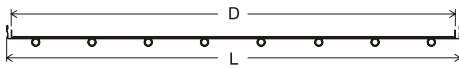
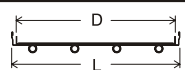
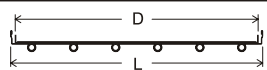
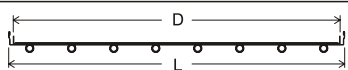

1 PRODUCT DESCRIPTION

1.1 Models, dimensions, weights, water contents - Tab.1

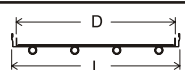
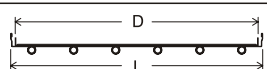
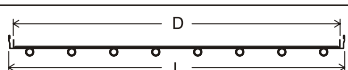
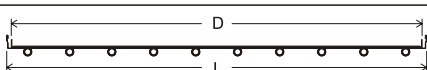
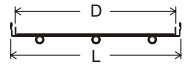
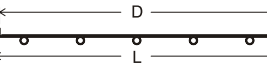
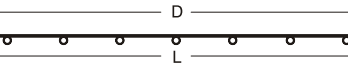
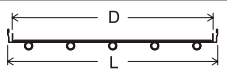
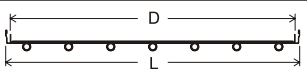
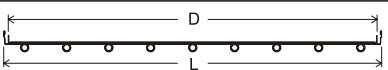
Interval of pipe mm	External pipe diameter mm	Cross section	Model	Nominal thermal emission ^(*) $\Delta T = 55 \text{ K}$ W/m	Total width L mm	Distance of suspensions D mm	
150	21,3		2/150 1/2"	180	300	270	
150	21,3		4/150 1/2"	309	600	570	
150	21,3		6/150 1/2"	431	900	870	
150	21,3		8/150 1/2"	554	1200	1170	
150	26,9		2/150 3/4"	190	300	270	
150	26,9		4/150 3/4"	318	600	570	
150	26,9		6/150 3/4"	449	900	870	
150	26,9		8/150 3/4"	581	1200	1170	
111	21,3		4/100 1/2"	278	450	420	
111	21,3		6/100 1/2"	413	675	650	
111	21,3		8/100 1/2"	516	900	870	
111	21,3		10/100 1/2"	616	1120	1090	
111	26,9		4/100 3/4"	279	450	420	
111	26,9		6/100 3/4"	415	675	650	
111	26,9		8/100 3/4"	534	900	870	
111	26,9		10/100 3/4"	650	1120	1090	
NON-STANDARD PANELS	150	21,3		3/150 1/2"	244	450	420
	150	21,3		5/150 1/2"	370	750	720
	150	21,3		7/150 1/2"	492	1050	1020
	111	21,3		5/100 1/2"	347	565	535
	111	21,3		7/100 1/2"	466	790	760
	111	21,3		9/100 1/2"	566	1010	980

Empty weight		Weight with water		Water contents (**) dm ³ /m
Panel (**) kg/m	Header kg	Pannel (**) kg/m	Header kg	
4,7 5,4	1,1	5,23 5,84	1,8	0,53 0,44
8,7 10,1	2,0	9,75 10,98	3,3	1,05 0,88
12,7 14,9	2,9	14,28 16,21	4,8	1,58 1,31
16,8 19,7	3,8	18,90 21,45	6,3	2,10 1,75
5,1 6,1	1,1	6,00 6,88	1,8	0,90 0,78
9,7 11,6	2,0	11,50 13,16	3,3	1,80 1,56
14,3 17,1	2,9	16,99 19,45	4,8	2,69 2,35
18,9 22,6	3,8	22,49 25,73	6,3	3,59 3,13
7,6 9,1	1,5	8,65 9,98	2,5	1,05 0,88
11,0 13,1	2,1	12,58 14,41	3,6	1,58 1,31
14,5 17,4	2,8	16,60 19,15	4,7	2,10 1,75
18,0 21,8	3,5	20,63 23,99	5,8	2,63 2,19
8,7 10,5	1,5	10,50 12,06	2,5	1,80 1,56
12,6 15,3	2,1	15,29 17,65	3,6	2,69 2,35
16,7 20,4	2,8	20,29 23,53	4,7	3,59 3,13
20,9 25,5	3,5	25,39 29,41	5,8	4,49 3,91
6,7 7,8	1,5	7,49 8,46	2,5	0,79 0,66
10,8 12,6	2,4	12,11 13,69	4,1	1,31 1,09
14,9 17,4	3,4	16,74 18,93	5,7	1,84 1,53
9,3 11,1	1,8	10,61 12,19	3,1	1,31 1,09
12,8 15,3	2,5	14,64 16,83	4,2	1,84 1,53
16,3 19,6	3,2	18,67 21,57	5,3	2,37 1,97

(*) Nominal thermal emission as per EN 14037, based on tests carried out at the HLK laboratory at the University of Stuttgart.
This emission is relative to $\Delta T = 55 \text{ K}$, where ΔT is the difference between the average temperature of the fluid and the ambient temperature

(**) Top line: with electro-welded pipe
Lower line: pipe with no welding

Maximum operating pressure: 6 bar.

The suspension brackets for the radiant panel are designed to support a weight without breaking that is five times greater than the weight of the panel including water.

The panel is able to support a load which is three times its own weight, including water, with no permanent deformation.



04

EN 14037-1 Ceiling mounted radiant panels
Maximum operating pressure: 6 bar

1.2 Construction

ECOPAN radiant panels are made by permanently inserting pipes in a suitably shaped plate of steel sheet metal, including the side edges.

The latest technologies are used to make circular grooves in the plate at regular distances.

The pipes are inserted into these housings. The profile of the plate wraps around two thirds of the circumference of each single pipe to hold it in place.

At the top, at intervals of about one metre, transversal brackets are placed. They make the entire system rigid and allow the support ties to be attached. At the worksite, the insulating mat provided is inserted between the side edges.

ECOPAN panels have tested electro-welded steel pipes (measuring either 1/2" or 3/4"). They are used in systems supplied with water at up to 120 °C.

For superheated water, steam, heat-transmitting oil, etc., steel pipes are used that are not welded, made of steel, and measure 1/2" or 3/4" or that have similar characteristics.

1.3 Production, modularity

ECOPAN radiant panels are produced in a variety of models:

- with pipes spaced at 150 mm, there are seven models with pipes of 1/2" and four with pipes of 3/4"
- with pipes spaced at 111 mm, there are seven models with pipes of 1/2" and four with pipes of 3/4".

Table 1 provides a summary of the range of products.

The sheet metal used to make plates is 0.6 mm thick and about 2 metres long. They are assembled to provide modules with lengths of either 4 or 6 metres.

Fig. 1 shows the dimensions of the modules of 4 or 6 metres that make up the radiant panels.

By combining these modules, it is possible to obtain radiant panels of any length in multiples of two, starting from a minimum length of 4 metres.

To ensure continuity of the panels at the points of welding of the various modules, joint covers are provided that have the same cross section as the panel. They are installed using steel clips.

1.4 Suspension brackets

Suspension brackets are to be placed on the panels about one every metre.

Fig. 2 shows the exact distance between the brackets.

When putting the panels in service, there should normally be one suspension every two metres.

The panels with pipes of 3/4" may have spacing increased by up to 30%.

Panels with a width of 60 cm or less may have suspension points with a distance of over 3 metres between them.

Distances between suspensions which are greater than those indicated above may lead to permanent deformation.

1.5 Headers

The headers have a square cross section (50x50 mm) for panels with electro-welded pipes and a round cross-section (Ø 60 mm) for panels with pipes without welding.

Different types of work are provided (fig. 3) depending on the fluid used and the type of supply.

They are normally provided welded to the panels.

1.6 Painting

After undergoing a phosphating treatment, the panels are painted by immersion using water-soluble paints with non-toxic epoxy resin base. They are then sent to a kiln.

The standard colour is RAL 7032 silicon grey.

This painting is resistant up to 170°C with water systems and up to 140°C for steam systems.

On request, and for higher temperatures, the panels can be treated with special paints.

For colours other than the standard colour, after washing, de-greasing and phosphating, the panels are painted with powder treatment that is free of harmful substances.

1.7 Insulation

Standard EN 14037 requires the laboratory that tests the emission of the panels to provide them with a layer of rock wool with a thickness of 40 mm, minimum density 25 kg/m³, thermal conductivity 0.04 W/mK at 40 °C, covered on the upper side by aluminium foil.

The insulating material provided by ECOPAN with the panels is non-carcinogenic fibreglass wool, compliant with directive 97/69/EC, implemented in Italy by means of the decree of the Ministry of Health dated 1 September 1998, with a thickness of 40 mm and covered on the upper side with aluminium foil.

For technical data of the insulation, see *paragraph 4.2*.

The insulating mat is delivered in rolls. It is to be inserted between the edges of the upper side of the panel. It is easy to lay because there are no obstacles to obstruct this. This ensures perfect adherence to the radiant panel.

The mat is fixed using plugs that are placed in holes in the suspension bracket.

1.8 Operating temperature

ECOPAN radiant panels with electro-welded pipes are suitable for carrying fluids at temperatures of up to 120 °C. The version with pipes without welding can be used for fluids up to 180 °C.

1.9 Operating pressure

For panels that operate with hot water up to 120°C, the maximum pressure is 6 bar. The test pressure at the plant for each weld is 10 bar, and the initial test pressure of each model is 10.2 bar.

For panels with pipes without welding, the maximum operating pressure is 16 bar.

1.10 Special versions, accessories

- Panels with pipes of 1" without welding
- panels with pipes at intervals of 111 mm measuring 1/2" with 4 pipes - 6 pipes - 8 pipes with spaces for lamps
- anti-convection lateral skirts
- concealed side profiles for suspensions at variable intervals
- joint covers for pipe joints with sleeves for *press fitting*
- headers for assembly with *press fitting*
- insulation covers for heads of panels
- upper sheet metal protections for gymnasiums.

For a more detailed description, see *chapter 3* on accessories.

Fig.1 Longitudinal dimensions of the modules that make up the panels (mm)

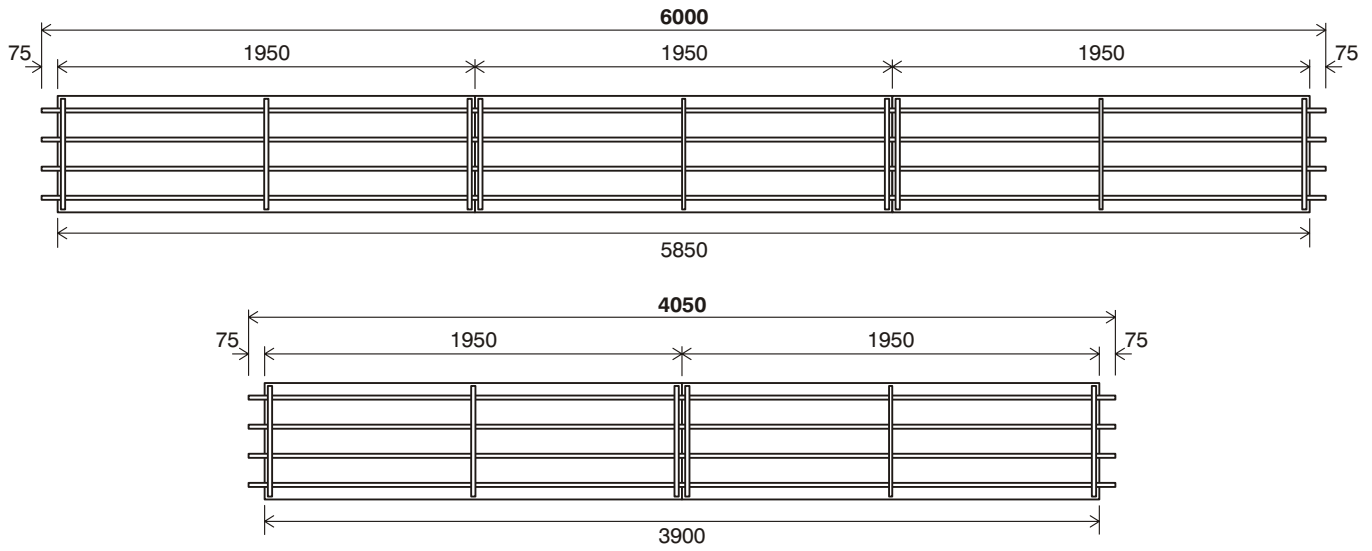

Fig.2 Suspension brackets (mm)

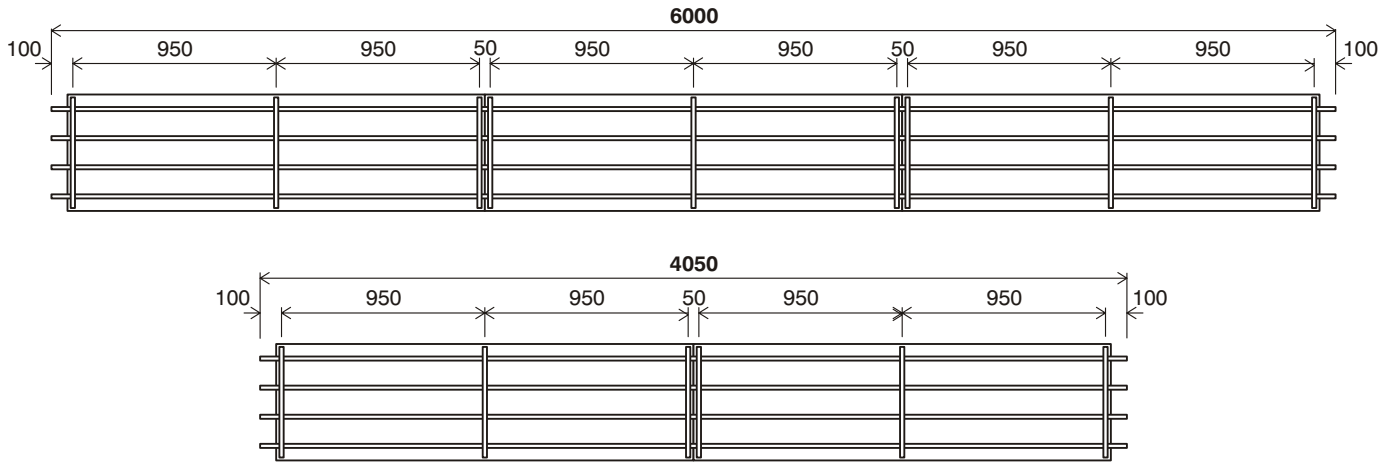
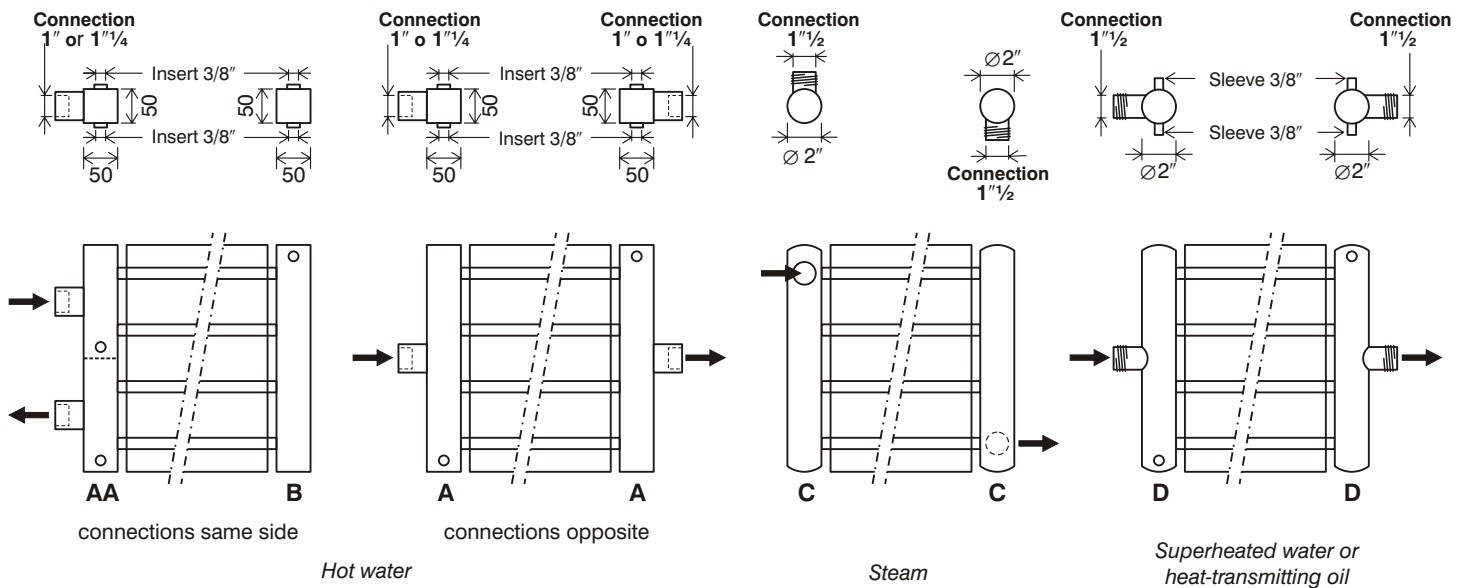

Fig.3 Headers - Execution AA, B, A, C, D (mm)



1.11 Components of the ECOPAN radiant panel

- ① Steel pipe, 1/2" or 3/4"
- ② Steel plates in single piece, including side edges
- ③ Reinforcing and suspension bracket
- ④ Insulating mat
- ⑤ Plug for fastening insulating mat
- ⑥ Header
- ⑦ Female threaded connection, 1 1/4 or 1"
- ⑧ Insert of 3/8" for vent or discharge
- ⑨ Suspension ties (chain, steel cables, etc.) not included in supply
- ⑩ Joint covers with fastening clips
- ⑪ Anti-convective side skirts (on request)

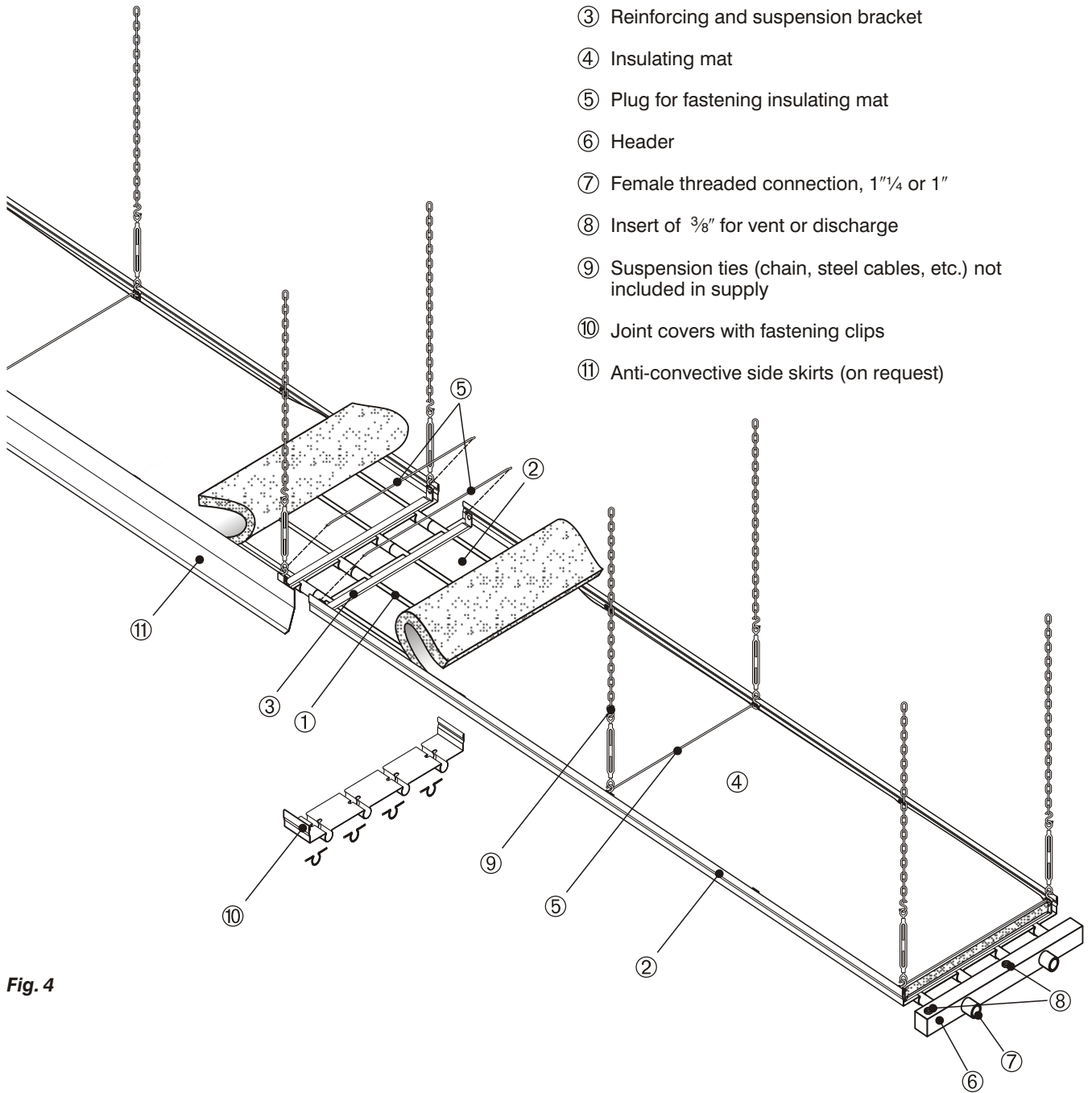
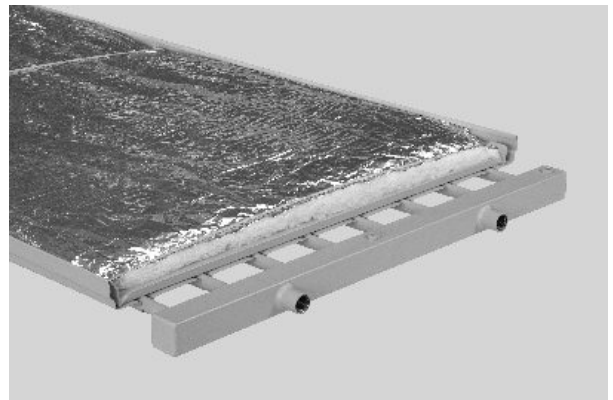
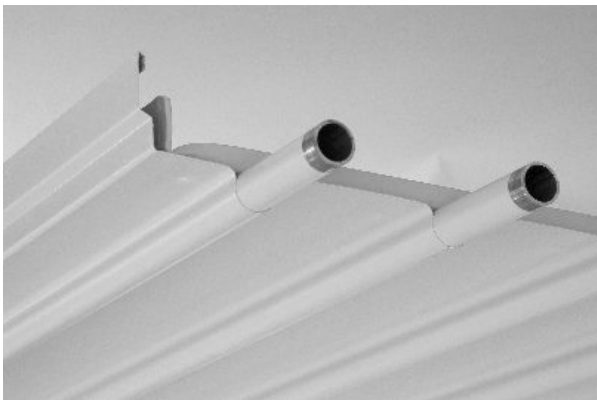

Fig. 4



2 DESIGN DATA

2.1 Guidelines for a correct choice

The ECOPAN range of radiant panels includes 22 different models:

- **with interval of 111 mm**,
seven with pipe of 1/2" and four with pipe of 3/4"
- **with interval of 150 mm**,
seven with pipe of 1/2" and four with pipe of 3/4".

Each model can be provided with electro-welded pipes or pipes with no welding.

All of these models provide the designer with a wide choice.

Tab. 2 shows the guidelines for choosing the type, diameter and interval of the pipes of the panels.

Tab.2 Selection criteria

SELECTION CRITERIA	pipes 1/2" interval:		pipes 3/4" interval:	
	111 mm	150 mm	111 mm	150 mm
Short radiant panels: up to 40 m with same-side connections, 80 m with opposite connections	•	•		
Long radiant panels: over 40 m with same side connections or 80 m with opposite connections			•	•
High-ceiling rooms	•		•	
Low-ceiling rooms ($h \leq 3.5$ meters)		•		•
Water flow rate per pipe from 250 to 500 l/h	•	•		
Water flow rate per pipe from 500 to 1000 l/h			•	•
Water heating fluid up to 120 °C	Electro-welded pipes			
Steam	Pipes with no welding or equivalent characteristics			
Superheated water				
Heat-transmitting oil				

2.2 Active length

Standard EN 14037 defines active length as the part of the panel with the same transversal cross-section, excluding headers and joint covers.

An ECOPAN panel of 6 metres has an active length (L_{act}) of 5.85 metres.

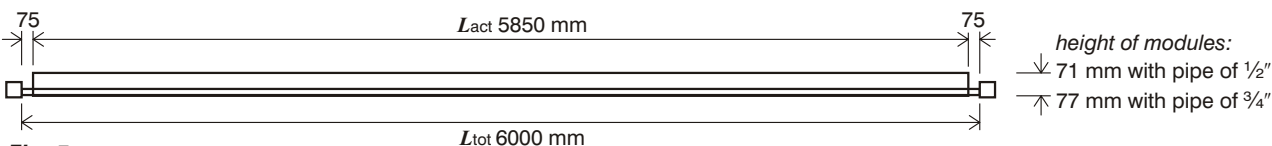

Fig. 5

An ECOPAN panel of 8 metres, formed of two modules each with a length of 4.05 metres, has an active length (L_{act}) of 7.8 metres.

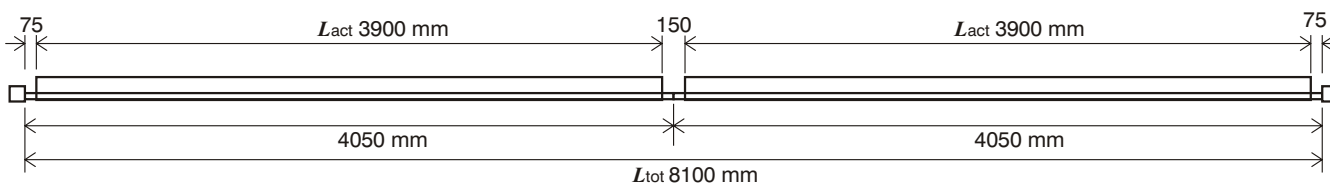

Fig. 6

An ECOPAN panel of 12 metres, formed of two modules of 6 metres, has an active length (L_{act}) of 11.70 metres.

An ECOPAN panel of 14 metres, formed of two modules of 4.05 metres and one module of 6 metres, has an active length (L_{act}) of 13.65 metres.

The examples above show that between the total length of the panels and their active length, there is a difference of about 3%. This is as opposed to an average difference of 5% in other panels available on the market.

In designing ECOPAN panels, an attempt has been made to reduce this difference to a minimum.

For this reason, a joint cover of 15 cm that is inserted to cover the joint between two modules has the same profile as the main sheet metal. Therefore it is also radiant. Laboratory tests show that it performs exactly like the active part of the panel.



2.3 Thermal emission

Tests based on European standard EN 14037 were carried out and certified by the HLK laboratory of the University of Stuttgart.

The thermal emissions of the ECOPAN radiant panels are shown in Tables 3 and 4.

Tables 5 and 6 provide the emissions of a pair of headers for the various models of panels.

The tables show the values of thermal power based on the difference (ΔT) between the average temperature of the fluid (t_m) and the ambient temperature (t_a).

The certified emission is for the active length of a radiant panel.

Tab.3 Table of thermal emissions per linear metre as per standard EN 14037

ECOPAN radiant panels - pipes of 1/2"

MODEL	4/100	5/100 (**)	6/100	7/100 (**)	8/100	9/100 (**)	10/100	2/150	3/150 (**)	4/150	5/150 (**)	6/150	7/150 (**)	8/150	
Interval of pipes mm	111	111	111	111	111	111	111	150	150	150	150	150	150	150	
Width mm	450	565	675	790	900	1010	1120	300	450	600	750	900	1050	1200	
No. of pipes - Ø	4 - 1/2"	5 - 1/2"	6 - 1/2"	7 - 1/2"	8 - 1/2"	9 - 1/2"	10 - 1/2"	2 - 1/2"	3 - 1/2"	4 - 1/2"	5 - 1/2"	6 - 1/2"	7 - 1/2"	8 - 1/2"	
$\Delta T = t_m - t_a$ (*) K	W/m	W/m	W/m	W/m	W/m	W/m	W/m	W/m	W/m	W/m	W/m	W/m	W/m	W/m	
20	84	105	125	141	156	171	186	55	75	95	114	132	151	170	
22	94	118	140	158	175	191	208	61	84	106	127	148	169	190	
24	104	130	156	175	194	212	231	68	93	117	141	164	187	210	
26	115	143	171	192	213	233	254	75	102	129	154	180	205	231	
28	125	156	186	210	232	255	277	81	111	140	168	196	224	251	
30	136	170	202	228	252	276	300	88	120	152	182	212	243	273	
32	146	183	218	246	272	298	324	95	130	164	197	229	262	294	
34	157	197	234	264	292	320	348	102	139	176	211	246	281	316	
36	168	210	251	282	313	343	373	109	149	188	226	263	300	337	
38	179	224	267	301	333	365	398	117	159	201	240	280	320	359	
40	191	238	284	320	354	388	423	124	168	213	255	297	339	382	
42	202	252	301	339	375	411	448	131	178	225	270	315	359	404	
44	213	267	318	358	396	435	473	138	188	238	285	332	379	427	
46	225	281	335	377	418	458	499	146	198	251	300	350	400	449	
48	236	295	352	397	439	482	524	153	208	263	316	368	420	472	
50	248	310	369	416	461	506	551	161	219	276	331	386	441	495	
52	260	325	387	436	483	530	577	169	229	289	347	404	461	519	
54	272	340	404	456	505	554	603	176	239	302	362	422	482	542	
ΔT_s standard temperature difference	55	278	347	413	466	516	566	616	180	244	309	370	431	492	554
56	284	354	422	476	527	578	630	184	250	315	378	440	503	566	
58	296	369	440	496	549	603	656	192	260	328	394	459	524	589	
60	308	385	458	516	572	628	683	199	271	342	410	477	545	613	
62	320	400	476	536	594	652	710	207	281	355	426	496	566	637	
64	332	415	494	557	617	677	738	215	292	368	442	515	588	661	
66	345	430	512	577	640	702	765	223	303	382	458	534	609	685	
68	357	446	531	598	663	728	793	231	313	395	474	552	631	710	
70	369	461	549	619	686	753	820	239	324	409	490	572	653	734	
72	382	477	568	640	709	779	848	247	335	423	507	591	675	759	
74	395	493	586	661	733	804	876	255	346	436	523	610	697	783	
76	407	508	605	682	756	830	904	263	357	450	540	629	719	808	
78	420	524	624	703	780	856	933	271	368	464	556	648	741	833	
80	433	540	643	725	803	882	961	280	379	478	573	668	763	858	
82	446	556	662	746	827	908	990	288	390	492	590	687	785	883	
84	458	572	681	768	851	935	1018	296	401	506	606	707	808	908	
86	471	588	700	789	875	961	1047	304	412	520	623	727	830	934	
88	484	604	719	811	899	987	1076	313	424	534	640	747	853	959	
90	497	621	738	833	923	1014	1105	321	435	548	657	766	876	985	
92	510	637	758	855	948	1041	1134	330	446	563	674	786	898	1010	
94	524	653	777	877	972	1068	1164	338	458	577	692	806	921	1036	
96	537	670	797	899	997	1095	1193	346	469	591	709	826	944	1062	
98	550	686	816	921	1021	1122	1222	355	481	606	726	847	967	1088	
100	563	703	836	943	1046	1149	1252	363	492	620	743	867	990	1114	
102	577	719	856	965	1071	1176	1282	372	504	635	761	887	1013	1140	
104	590	736	875	988	1095	1203	1312	381	515	649	778	907	1037	1166	
106	604	753	895	1010	1120	1231	1342	389	527	664	796	928	1060	1192	
108	617	770	915	1033	1145	1258	1372	398	538	678	813	948	1083	1219	
110	631	786	935	1055	1171	1286	1402	407	550	693	831	969	1107	1245	
112	644	803	955	1078	1196	1314	1432	415	562	708	848	989	1130	1272	
114	658	820	975	1101	1221	1342	1462	424	574	722	866	1010	1154	1298	
116	672	837	996	1124	1246	1369	1493	433	585	737	884	1031	1178	1325	
118	685	854	1016	1146	1272	1397	1524	441	597	752	902	1052	1202	1352	
120	699	872	1036	1169	1297	1426	1554	450	609	767	920	1072	1225	1379	

(*) ΔT = difference between the average temperature of the fluid and the ambient temperature (**) = non-standard panels

Tab.4 Table of thermal emissions per linear metre as per standard EN 14037

ECOPAN radiant panels - pipes of 3/4"

MODEL	4/100	6/100	8/100	10/100	2/150	4/150	6/150	8/150	
Interval of pipes mm	111	111	111	111	150	150	150	150	
Width mm	450	675	900	1120	300	600	900	1200	
No. of pipes - Ø	4 - 3/4"	6 - 3/4"	8 - 3/4"	10 - 3/4"	2 - 3/4"	4 - 3/4"	6 - 3/4"	8 - 3/4"	
$\Delta T = t_m - t_a$ (*) K	W/m	W/m	W/m	W/m	W/m	W/m	W/m	W/m	
20	84	126	161	196	58	97	137	176	
22	94	141	181	219	65	108	153	197	
24	105	156	200	243	72	120	169	219	
26	115	171	220	267	79	132	186	240	
28	126	187	240	292	86	144	203	262	
30	136	203	261	317	93	156	220	284	
32	147	219	281	342	100	168	237	307	
34	158	235	302	367	108	181	255	330	
36	169	252	323	393	115	193	273	353	
38	180	268	345	419	123	206	291	376	
40	192	285	366	446	131	219	309	399	
42	203	302	388	472	138	231	327	423	
44	215	319	410	499	146	245	346	447	
46	226	336	432	526	154	258	364	471	
48	238	353	454	553	162	271	383	495	
50	250	370	477	581	170	284	402	519	
52	261	388	499	608	178	298	421	544	
54	273	406	522	636	186	311	440	568	
ΔT_s standard temperature difference	55	279	415	534	650	190	318	449	581
56	285	423	545	664	194	325	459	593	
58	298	441	568	692	202	338	478	618	
60	310	459	592	721	210	352	498	644	
62	322	477	615	749	219	366	517	669	
64	334	496	638	778	227	380	537	694	
66	347	514	662	807	235	394	557	720	
68	359	532	686	836	244	408	577	746	
70	372	551	710	865	252	422	597	772	
72	384	570	734	895	261	436	617	798	
74	397	588	758	924	269	451	637	824	
76	410	607	782	954	278	465	658	850	
78	423	626	807	984	286	479	678	877	
80	435	645	831	1014	295	494	698	903	
82	448	664	856	1044	304	509	719	930	
84	461	683	881	1074	312	523	740	957	
86	474	702	905	1104	321	538	761	984	
88	488	722	930	1135	330	553	781	1011	
90	501	741	955	1166	339	567	802	1038	
92	514	760	981	1196	348	582	823	1065	
94	527	780	1006	1227	357	597	844	1092	
96	540	800	1031	1258	366	612	866	1120	
98	554	819	1057	1289	375	627	887	1147	
100	567	839	1082	1321	384	642	908	1175	
102	581	859	1108	1352	393	657	930	1203	
104	594	879	1134	1383	402	673	951	1230	
106	608	899	1159	1415	411	688	973	1258	
108	621	919	1185	1447	420	703	994	1286	
110	635	939	1211	1479	429	718	1016	1314	
112	649	959	1237	1511	438	734	1038	1343	
114	662	979	1264	1543	447	749	1060	1371	
116	676	1000	1290	1575	457	765	1082	1399	
118	690	1020	1316	1607	466	780	1104	1428	
120	704	1040	1343	1639	475	796	1126	1456	

(*) ΔT = difference between the average temperature of the fluid and the ambient temperature

**Tab.5 Table of thermal emissions of headers as per standard EN 14037
pair of ECOPAN headers ECOPAN - pipes of 1/2"**

MODEL	4/100	5/100 (**)	6/100	7/100 (**)	8/100	9/100 (**)	10/100	2/150	3/150 (**)	4/150	5/150 (**)	6/150	7/150 (**)	8/150	
Interval of pipes mm	111	111	111	111	111	111	111	150	150	150	150	150	150	150	
Width mm	450	565	675	790	900	1010	1120	300	450	600	750	900	1050	1200	
No. of pipes - Ø	4 - 1/2"	5 - 1/2"	6 - 1/2"	7 - 1/2"	8 - 1/2"	9 - 1/2"	10 - 1/2"	2 - 1/2"	3 - 1/2"	4 - 1/2"	5 - 1/2"	6 - 1/2"	7 - 1/2"	8 - 1/2"	
$\Delta T = t_m - t_a$ (*) K	W	W	W	W	W	W	W	W	W	W	W	W	W	W	
20	36	44	52	58	64	71	77	22	34	46	58	71	83	96	
22	40	50	59	66	73	80	87	25	38	52	66	80	94	108	
24	45	55	66	73	81	89	96	27	43	58	73	89	104	120	
26	49	61	73	81	90	98	107	30	47	64	81	98	115	133	
28	54	67	80	89	98	108	117	33	52	70	89	107	126	145	
30	59	74	87	97	107	117	128	36	57	77	97	117	137	158	
32	64	80	95	106	117	127	138	39	61	83	105	127	149	171	
34	69	86	102	114	126	137	149	42	66	90	113	137	160	184	
36	74	93	110	123	135	148	160	45	71	97	122	147	172	197	
38	80	99	118	132	145	158	171	48	76	103	130	157	184	211	
40	85	106	126	140	154	169	183	51	81	110	139	167	196	224	
42	90	113	134	149	164	179	194	55	86	117	147	177	208	238	
44	96	119	142	158	174	190	206	58	91	124	156	188	220	252	
46	101	126	150	168	184	201	218	61	96	131	165	199	232	266	
48	107	133	159	177	194	212	230	64	102	139	174	209	245	280	
50	113	140	167	186	205	223	242	68	107	146	183	220	257	294	
52	118	148	176	196	215	234	254	71	112	153	192	231	270	309	
54	124	155	184	205	226	246	266	74	118	161	201	242	283	323	
ΔT_s standard temperature difference	55	127	158	189	210	231	251	272	76	120	165	206	248	289	331
56	130	162	193	215	236	257	278	78	123	168	211	253	296	338	
58	136	169	202	225	247	269	291	81	129	176	220	265	309	353	
60	141	177	211	235	258	281	303	85	134	184	230	276	322	368	
62	147	184	220	245	269	292	316	88	140	191	239	287	335	383	
64	153	192	229	255	280	304	329	92	145	199	249	299	348	398	
66	159	200	238	265	291	316	342	95	151	207	259	310	362	413	
68	166	207	247	275	302	328	355	99	157	215	269	322	375	428	
70	172	215	257	286	313	341	368	102	162	223	278	334	389	444	
72	178	223	266	296	324	353	381	106	168	231	288	346	403	459	
74	184	231	276	306	336	365	394	110	174	239	298	358	416	475	
76	190	239	285	317	347	378	408	113	180	247	308	370	430	491	
78	197	247	295	328	359	390	421	117	186	255	319	382	444	506	
80	203	255	304	338	371	403	435	121	192	263	329	394	458	522	
82	209	263	314	349	382	415	448	124	198	272	339	406	472	538	
84	216	271	324	360	394	428	462	128	204	280	349	418	487	554	
86	222	279	334	371	406	441	476	132	210	288	360	431	501	570	
88	229	287	344	382	418	454	490	136	216	297	370	443	515	587	
90	235	296	354	393	430	467	504	140	222	305	381	456	530	603	
92	242	304	364	404	442	480	518	143	228	314	391	468	544	619	
94	249	312	374	415	454	493	532	147	234	323	402	481	559	636	
96	255	321	384	426	467	506	546	151	241	331	413	493	573	652	
98	262	329	394	438	479	520	560	155	247	340	424	506	588	669	
100	269	338	405	449	491	533	575	159	253	349	434	519	603	686	
102	276	346	415	460	504	547	589	163	260	357	445	532	618	702	
104	282	355	425	472	516	560	604	167	266	366	456	545	633	719	
106	289	364	436	483	529	574	618	171	272	375	467	558	648	736	
108	296	372	446	495	541	587	633	175	279	384	478	571	663	753	
110	303	381	457	507	554	601	647	179	285	393	489	584	678	770	
112	310	390	467	518	567	615	662	183	292	402	500	597	693	787	
114	317	399	478	530	580	628	677	187	298	411	511	610	708	804	
116	324	408	489	542	592	642	692	191	305	420	523	624	723	822	
118	331	417	500	554	605	656	707	195	311	429	534	637	739	839	
120	338	426	510	566	618	670	722	199	318	438	545	650	754	856	

(*) ΔT = difference between the average temperature of the fluid and the ambient temperature (**) = non-standard panels

**Tab.6 Table of thermal emissions of headers as per standard EN 14037
pair of ECOPAN headers ECOPAN - pipes of 3/4"**

MODEL	4/100	6/100	8/100	10/100	2/150	4/150	6/150	8/150	
Interval of pipes mm	111	111	111	111	150	150	150	150	
Width mm	450	675	900	1120	300	600	900	1200	
No. of pipes - Ø	4 - 3/4"	6 - 3/4"	8 - 3/4"	10 - 3/4"	2 - 3/4"	4 - 3/4"	6 - 3/4"	8 - 3/4"	
$\Delta T = t_m - t_a$ (*) K	W	W	W	W	W	W	W	W	
20	43	57	67	77	20	49	79	110	
22	49	65	76	87	23	55	89	124	
24	55	72	84	97	25	62	99	138	
26	60	80	94	107	28	68	110	152	
28	66	89	103	117	31	75	120	167	
30	72	97	112	128	34	82	131	181	
32	78	105	122	138	36	89	142	197	
34	84	114	132	149	39	96	153	212	
36	90	123	142	160	42	103	165	227	
38	97	132	152	171	45	111	176	243	
40	103	141	162	183	48	118	188	259	
42	109	150	172	194	51	126	200	275	
44	116	160	183	206	54	133	212	291	
46	122	169	193	217	57	141	224	308	
48	129	179	204	229	60	149	236	324	
50	136	189	215	241	63	157	249	341	
52	143	199	226	253	66	165	261	358	
54	149	209	237	265	69	173	274	375	
ΔT_s standard temperature difference	55	153	214	243	271	71	177	280	384
56	156	219	248	277	73	181	287	393	
58	163	229	260	290	76	189	300	410	
60	170	240	271	302	79	198	313	428	
62	178	250	283	315	82	206	326	445	
64	185	261	294	327	86	214	339	463	
66	192	271	306	340	89	223	352	481	
68	199	282	318	353	92	232	366	499	
70	206	293	330	366	96	240	379	517	
72	214	304	342	379	99	249	393	536	
74	221	315	354	392	102	258	407	554	
76	229	326	367	405	106	267	421	573	
78	236	337	379	418	109	276	435	592	
80	244	349	391	432	113	285	449	610	
82	251	360	404	445	116	294	463	629	
84	259	372	416	459	120	303	477	648	
86	267	383	429	472	123	312	491	668	
88	274	395	442	486	127	321	505	687	
90	282	407	455	500	130	330	520	706	
92	290	419	467	514	134	340	534	726	
94	298	431	480	528	138	349	549	745	
96	306	443	494	542	141	359	564	765	
98	314	455	507	556	145	368	578	785	
100	322	467	520	570	149	378	593	804	
102	330	479	533	584	152	387	608	824	
104	338	491	546	598	156	397	623	844	
106	346	504	560	612	160	407	638	865	
108	354	516	573	627	163	417	653	885	
110	362	529	587	641	167	426	668	905	
112	370	541	601	656	171	436	684	925	
114	379	554	614	670	175	446	699	946	
116	387	567	628	685	179	456	714	967	
118	395	579	642	700	182	466	730	987	
120	404	592	656	714	186	476	745	1008	

(*) ΔT = difference between the average temperature of the fluid and the ambient temperature

2.4 Corrective coefficients for high installation heights

When the height of installation of the radiant panels is over 6 metres, consideration must be made of the reduced radiant effects on the occupants and for the luminous bodies. Therefore, a greater heating surface will be required.

Table 7 below shows the coefficients of reduction in radiance for installation heights of over 6 meters.

Tab. 7

H(m)	6	7	8	9	10	11	12	13	14	16	18	20
f_n	1,00	0,97	0,95	0,92	0,90	0,88	0,86	0,84	0,82	0,79	0,76	0,73

Example: in a warehouse where the panels are installed at a height of 10 metres, the number of panels obtained by dividing the total thermal requirement by the emission per metre of the selected model must then be divided by $f_n = 0.9$.

However, this must be evaluated on a case-by-case basis, especially when high levels of power are involved. Consideration should be made of the size of the solid angle with which the occupant sees the surface of all of the installed panels. This is illustrated more clearly by the laws of thermal exchange by radiance. All of this is also dependent on the cold surface around the occupant. From our experience, and without entering into issues that are difficult to resolve which would involve factors of shape (fraction of the total radiant power which starts from one surface and reaches another one), we suggest this simple method:

- calculate the cold surface of the external walls below the panels (perimeter x height of installation)
- determine the ratio between this surface and the floor surface
- if this ratio is greater than 1, the corrective coefficients for elevated heights are applied; if it is less than 1, they are not applied.

Panels supplied with water up to 120°C normally do not require the installation of side skirts.

These are used in systems that are to heat single zones or where the carrier fluid is at a very high temperature.

For special installations consult the ECOPAN technical department.

2.5 Corrective coefficient for inclined panels

ECOPAN radiant panels can be installed inclined, following the geometry of the roof.

They can be inclined either transversally or longitudinally.

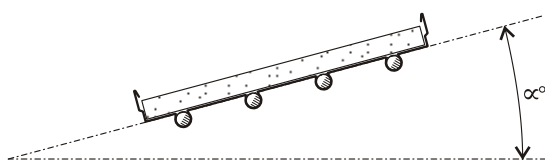

Fig.7 Transversally inclined panel

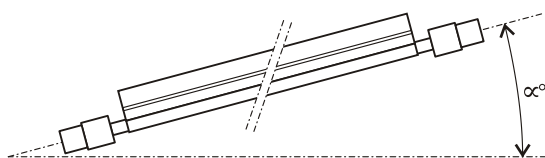

Fig.8 Longitudinally inclined panel

Inclination favours convective movement. There is an increase in total emission while emission from radiance is decreased.

The new emission value is determined by multiplying the thermal emissions in Table 3 and 4 by the corrective coefficient shown in Fig. 9, based on the angle of inclination.

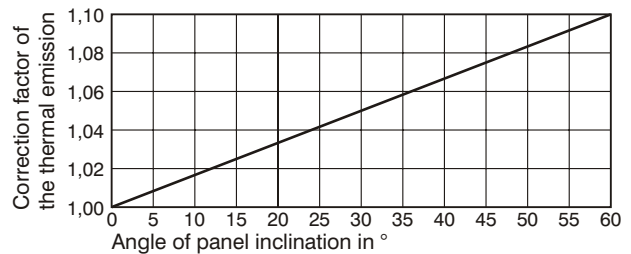

Fig.9 Corrective coefficient of emissions for inclined panels

2.6 Distance between radiant panels

To ensure even distribution of heat, the distance between radiant panels must be equal to or less than their installation height.

The distance from the cold wall must not be greater than 1/3 of the height.

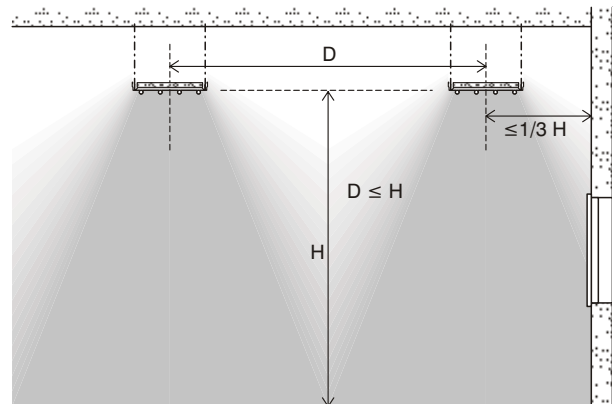

Fig.10 Distance between radiant panels

2.7 Minimum height of installation

When making calculations for a radiant panel system, keep in mind that the required surface area of the panels decreases as the temperature of the carrier fluid increases.

In order to ensure physiological well-being of individuals and prevent excessive radiance, limits must be set for the minimum height of installation of the panels.

Table 8 provides the minimum height of installation for the panels, based on the average temperature of the carrier fluid and the interval between pipes.

Tab.8 Minimum height of installation based on average temperature of carrier fluid

average temperature of supply fluid °C	Interval of pipes 111 mm	Interval of pipes 150 mm
	H min (m)	H min (m)
60	3,80	3,60
70	4,10	3,90
80	4,30	4,10
90	4,50	4,30
100	4,70	4,50
110	4,90	4,70
120	5,10	4,90

2.8 Arrangement of ceiling mounted panels

In laying out and arranging the panels, it is advisable to comply with the following:

- if possible, install the panels parallel to the longest wall of the building
- keep a distance between the wall and the first panel that is not greater than a third of the installation height
- provide panels that are as long as possible, taking into account emissions and pressure drops
- determine the number of panels, taking into account the height of installation and the resulting area of radiance
- determine the models of panels based on their thermal power. Place models with greater emission near the

outer walls to better contrast cold radiation to

- check that the minimum height of installation is compatible with the temperature of the heating fluid being used. For installation at reduced height, choose panels that are narrower or that have a greater interval between pipes.

Figures 11, 12 and 13 clearly show how correct layout of panels provides even radiance and an ideal ambient temperature.

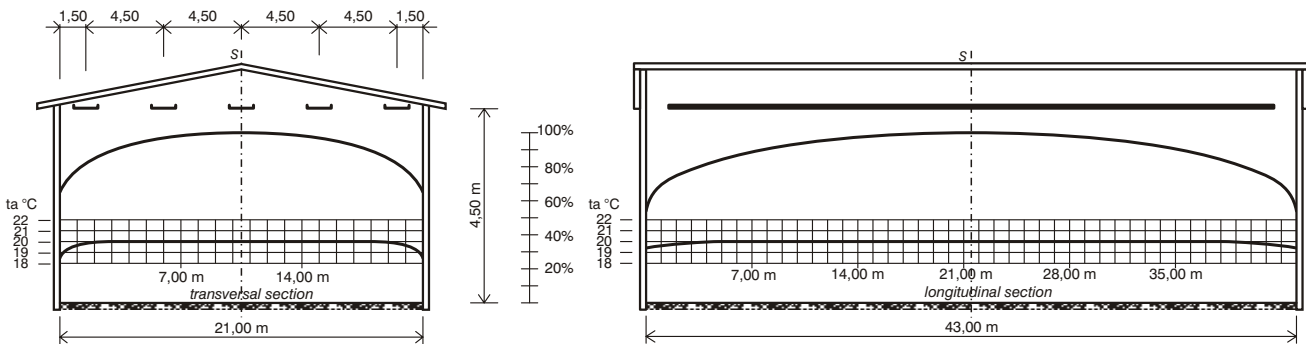

Fig.11 Intensity of radiance and ambient temperature with even distribution of panels of the same power parallel to the long side of the building

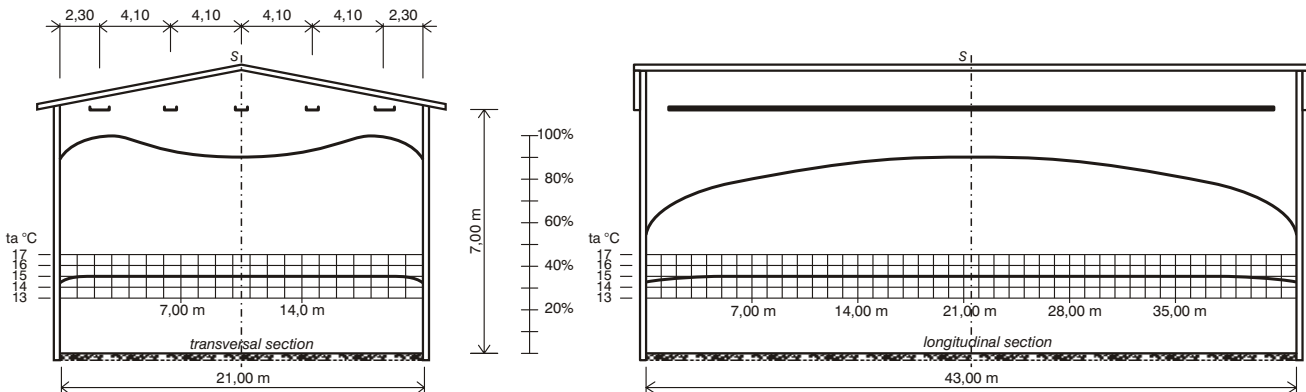

Fig.12 Intensity of radiance and ambient temperature with higher power panels nearer the external walls

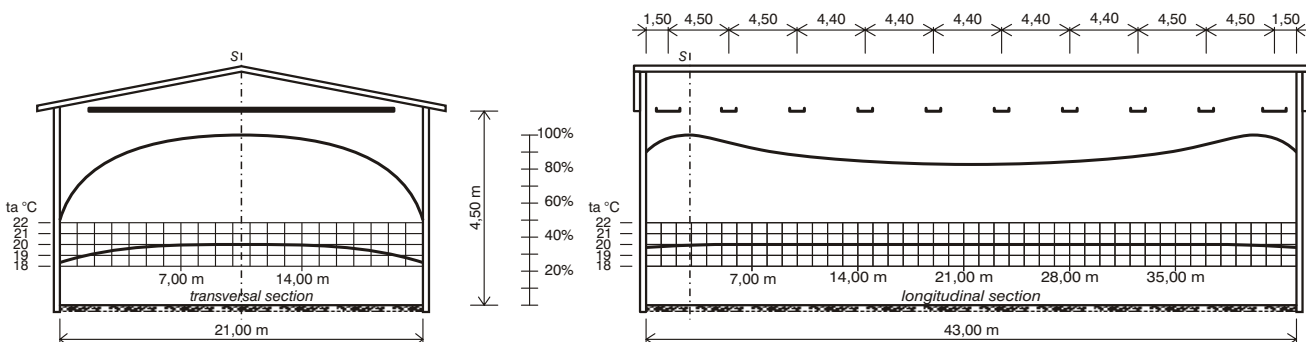

Fig.13 Intensity of radiance and ambient temperature with panels parallel to the short side of the building

2.9 Examples of calculation of radiant panels

While respecting the structural needs of the building and the layout of any scaffolding, machinery, and so on, it is always advisable to place the radiant panels parallel to the longest side.

In this way, you can have panels of greater length while reducing the number. You will thus also reduce the fluid distribution network, resulting in lower system costs.

The length and layout of the panels must be such that it evenly covers the entire area to be heated.

In the following examples, we have hypothesized similar rooms but with different heights, or with different layouts of the panels.

First example (Fig. 11 and 14)

Consider a warehouse with the following dimensions: 43×21 metres with average height of 5.5 metres, for a volume of approximately 4,967 m³.

The thermal requirement has been estimated as about 95 kW.

Ambient temperature $t_a = 20^\circ\text{C}$.

Installation height of the panels 4.5 m.

Maximum interval between panels 4.5 m.

Consider 5 panels with a length of 40 m, arranged as in Fig. 14, for a total length of 200 m.

Dividing the thermal requirement by the total length of the panels gives the thermal emission per metre:

$$95'000 \text{ W}/200 \text{ m} = 475 \text{ W/m}$$

Fixing:

water delivery temperature $t_1 = 80^\circ\text{C}$

water return temperature $t_2 = 70^\circ\text{C}$

the average temperature of the water will be:

$$t_m = \frac{t_1 + t_2}{2} = \frac{80 + 70}{2} = 75^\circ\text{C}$$

and the ΔT is: $\Delta T = t_m - t_a = 75^\circ\text{C} - 20^\circ\text{C} = 55^\circ\text{C}$

From Table 3 with $\Delta T = 55^\circ\text{C}$ and considering model 8/100-1/2", one obtains a thermal emission of 516 W/m.

The total installed thermal power is:

$$200 \text{ m} \times 516 \text{ W/m} = 103'200 \text{ W}$$

thermal power sufficient to cover thermal requirement.

Having a distribution of only 5 connections to balance the circuit, it is advisable to use calibration valves on the panels.

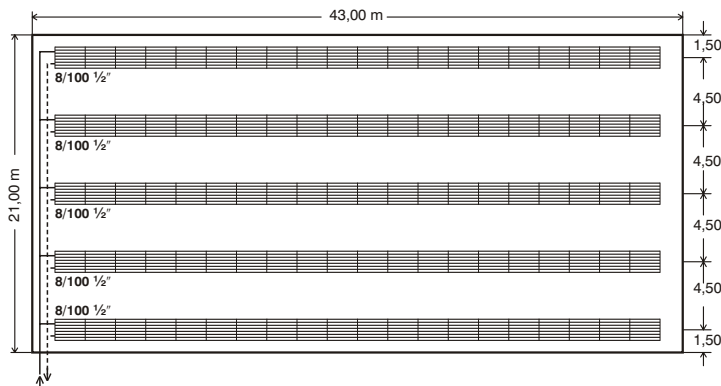

Fig.14 Example of ECOPAN panels in warehouse with average height of 5.5 m and parallel panels on greater side

Second example (Fig. 12 and 15)

Consider a warehouse with the previous dimensions: 43×21 metres with average height of 8.2 metres, for a volume of approximately 7,405 m³.

The thermal requirement has been estimated as about 120 kW.

Ambient temperature $t_a = 15^\circ\text{C}$.

Installation height of the panels 7 m.

Maximum interval between panels 7 m.

Consider 5 panels with a length of 40 m, arranged as in Fig. 15, for a total length of 200 m.

As previously mentioned in paragraph 2.4, it is not necessary to increase the number of panels to be installed.

Dividing the thermal requirement by the total length of the panels gives the average thermal emission per metre:

$$120'000 \text{ W}/200 \text{ m} = 600 \text{ W/m}$$

Fixing:

Water delivery temperature $t_1 = 80^\circ\text{C}$

Water return temperature $t_2 = 70^\circ\text{C}$

the average temperature of the water will be:

$$t_m = \frac{t_1 + t_2}{2} = \frac{80 + 70}{2} = 75^\circ\text{C}$$

and the ΔT is: $\Delta T = t_m - t_a = 75^\circ\text{C} - 15^\circ\text{C} = 60^\circ\text{C}$

On the side there are 2 panels model 10/100-1/2" with a length of 40 metres (80 m total). In the central area there are 3 panels model 8/100-1/2" with a length of 40 metres (120 m total).

Table 3 with $\Delta T = 60^\circ\text{C}$ provides a thermal emission of:

$$683 \text{ W/m for panels of } 10/100-1/2''$$

$$572 \text{ W/m for panels of } 8/100-1/2''$$

The total thermal power of the single models is:

$$80 \text{ m} \times 683 \text{ W/m} = 54'640 \text{ W}$$

$$120 \text{ m} \times 572 \text{ W/m} = 68'640 \text{ W}$$

for a total of:

$$54'640 + 68'640 = 123'280 \text{ W}$$

thermal power sufficient to cover the 120 kW required.

Having a distribution of only 5 connections to balance the circuit, it is advisable to use calibration valves on the panels.

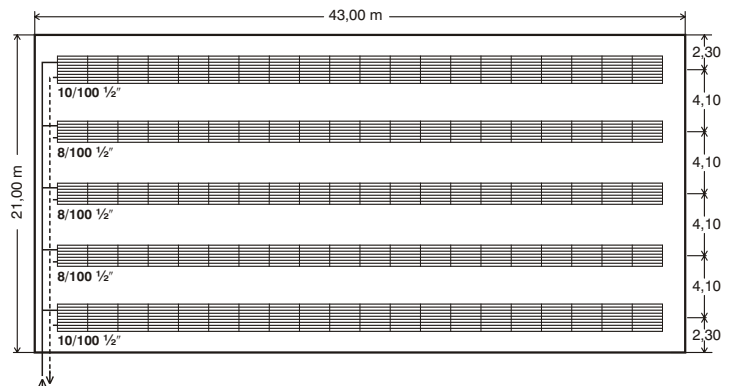

Fig.15 Example of ECOPAN panels in warehouse with average height of 5.5 m and parallel panels on greater side

Third example (Fig. 13 and 16)

Consider a warehouse, again with the same dimensions: 43×21 metres with average height of 5.5 metres, for a volume of approximately 4,967 m³.

The thermal requirement has been estimated as about 95 kW.

Ambient temperature $t_a = 20^\circ\text{C}$.

Installation height of the panels 4.5 m.

Maximum interval between radiant panels 4.5 m.

Suppose it is not possible to place the panels parallel to the longer wall of the warehouse, but that they need to be placed parallel to the shorter one.

Consider 10 panels with a length of 18 m, arranged as in Fig. 16, for a total length of 180 m.

Dividing the thermal requirement by the length gives the average thermal emission per metre:

$$95\,000\text{ W}/180\text{ m} = 528\text{ W/m}$$

Fixing:

Water delivery temperature $t_1 = 80^\circ\text{C}$

Water return temperature $t_2 = 70^\circ\text{C}$

the average temperature of the water will be:

$$t_m = \frac{t_1 + t_2}{2} = \frac{80 + 70}{2} = 75^\circ\text{C}$$

And the ΔT is: $\Delta T = t_m - t_a = 75^\circ\text{C} - 20^\circ\text{C} = 55^\circ\text{C}$

On the sides there are 2 panels model 10/100-1/2" with a length of 18 meters (36 m total) and in the central zone 8 panels model 8/100-1/2" with a length of 18 metres (144 m total).

Table 3 with $\Delta T=55^\circ\text{C}$ provides a thermal emission of:

616 W/m for panels 10/100-1/2"

516 W/m for panels 8/100-1/2"

The total thermal power of the single models is:

$$36\text{ m} \times 616\text{ W/m} = 22\,176\text{ W}$$

$$144\text{ m} \times 516\text{ W/m} = 74\,304\text{ W}$$

for a total of:

$$22\,176 + 74\,304 = 96\,480\text{ W}$$

Thermal power sufficient to cover thermal requirement.

Having a distribution of 10 connections and short panels, the circuit can be balanced using "inverse return".

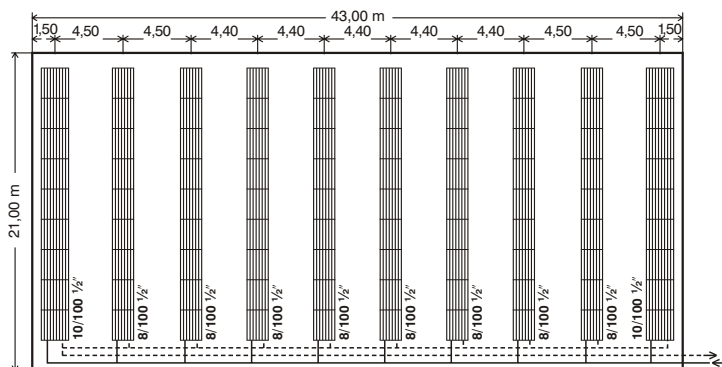

Fig.16 Example of ECOPAN panels in warehouse with average height of 5.5 m and parallel panels on smaller side

2.10 Effects on luminosity originating from the covering

Ceiling mounted panels, if located carefully, do not reduce the light from skylights in the roof.

In many applications, the effect has been checked both before and after the installation of the panels.

In most cases, the reduction of light in the warehouses was negligible.



2.11 Use in cooling systems

ECOPAN radiant panels can be used in cooling systems.

This application provides the same benefits as the use of panels for heating, which include:

- very limited thermal inertia
- no air movement, which is bothersome to persons affected by it
- no moving parts
- no maintenance
- no wear
- no noise
- limited amount of electrical consumption and electrical systems
- possible to install by zones
- minimum dimensions.

This is a system that pleasantly cools the rooms but does not allow air treatment, except in combination with other specific units.

In this case, the insertion of cold surfaces contrasts the radiance from hot surfaces, providing the occupants with well-being.

To prevent condensation on the radiant surface, the surface temperature of the panels needs to be greater than the dew point of the ambient air.

Thermal power in cooling mode should be requested from the ECOPAN technical department, which is available for suggestions for every single project.

2.12 Diagrams of system balancing and power supply

Radiant panels supplied by hot water can be connected to the distribution network with inlet and outlet of the fluid on opposite sides (type A headers) or with connections on the same side (type AA and B headers).



Fig.17 Connection with fluid inlet and outlet on opposite sides



Fig.18 Connection with fluid inlet and outlet on same side

In the first case, all the pipes of the panels are supplied in parallel and the water flow is divided equally among them. In the second case, half the pipes are connected in series with the other half, thus doubling the flow rate of each pipe. The following are some examples of possible supply layouts.



Fig.19 ECOPAN radiant panels in parallel with opposite connections

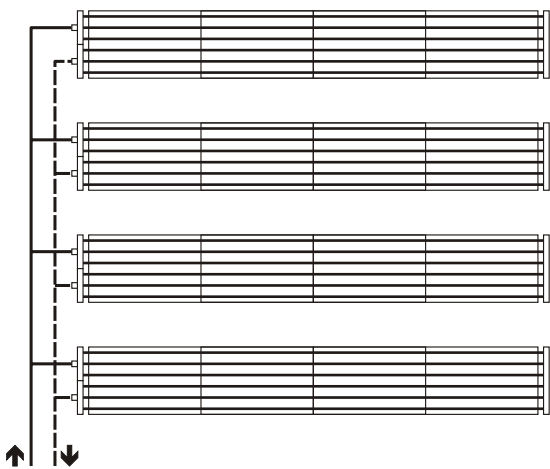

Fig.20 ECOPAN radiant panels in parallel with same-side connections

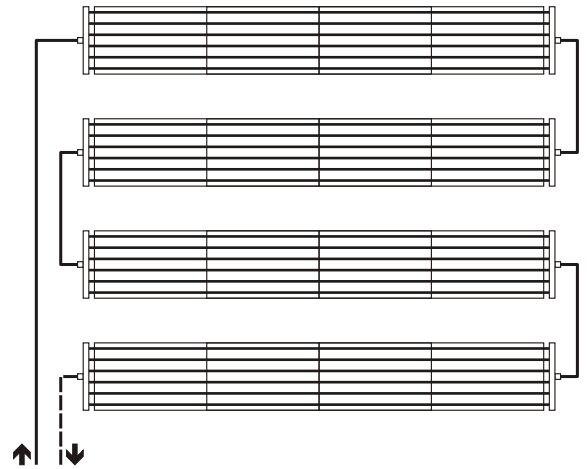

Fig.21 ECOPAN radiant panels in series with opposite connections

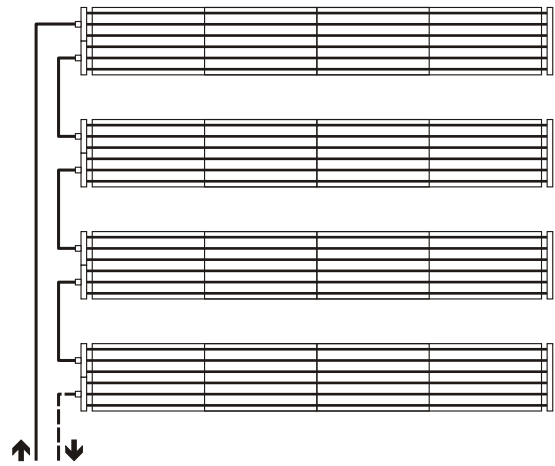
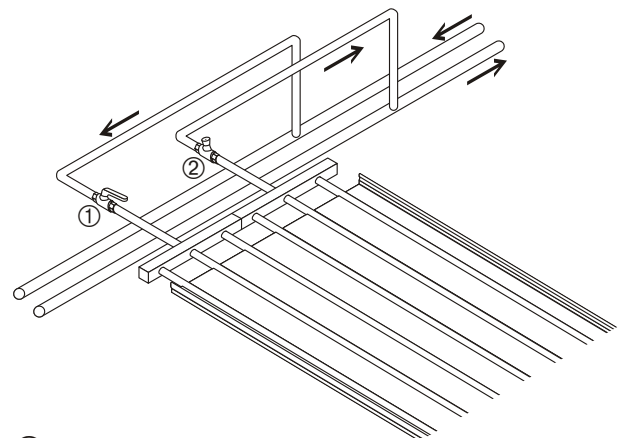

Fig.22 ECOPAN radiant panels in series with same-side connections

In every heating system, it is important for the heating bodies to be supplied with the proper amount of fluid as established during the design phase.

The radiant panels must also be supplied in a perfectly balanced manner.

To balance them, provide calibration valves as necessary which are to be adjusted at start-up.



① Cut-off valve

② Cut-off and balancing valve

If there are many panels, it is advisable to provide a set of pipes for "inverse return" (Fig. 23 and 24) which balances the system. This solution is expensive and it is not always feasible.

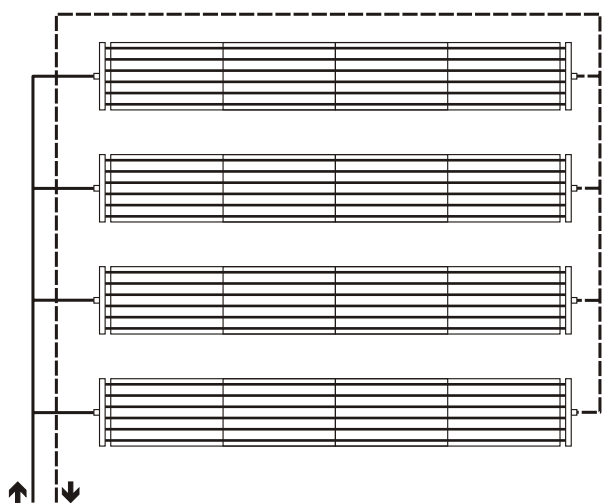

Fig.23 ECOPAN radiant panels with opposite connections and with "inverse return" pipes

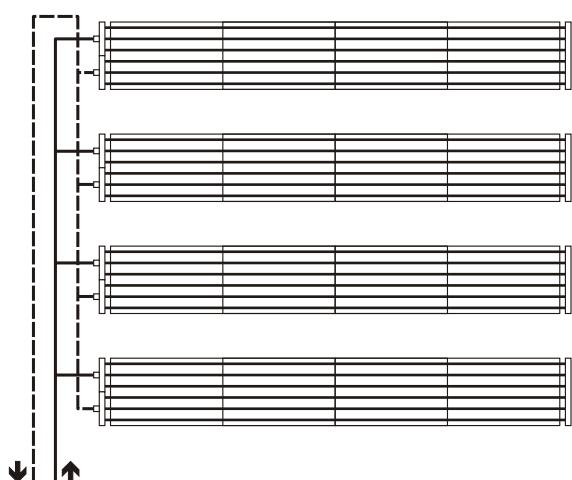

Fig.24 ECOPAN radiant panels with same-side connections and with "inverse return" pipes

2.13 Flow rate and speed of water in the panels

If the speed of the water in the pipes of the panels is too low, the water will not be able draw off the air. This may cause a shutdown in circulation with a substantial reduction in the emission of the panel.

When determining the size of the systems, it is advisable to make sure that the speed of the water in each single pipe is never less than 0.23 m/s in pipes of 1/2" and 0.32 m/s in pipes of 3/4".

In hot water radiating panels, it is advisable to have a temperature difference of 10°C between the delivery and return headers. This is considered an acceptable compromise between the size of the network and the need for a high surface temperature.

Also, pressure drops may be considered acceptable in pipes of the panels which do not exceed 200 ÷ 250 Pa/m.

2.14 Pressure drops of panel pipes

Table 9 shows the values of the pressure drop in Pa/m and of the speed in m/s based on the water flow rate of each pipe in a panel, with an average water temperature of 75 °C.

This is true both for panels with electro-welded pipes and for those with pipes with no welding.

Tab.9 Pressure drop in Pa/m pipes in ECOPAN radiant panels

Water flow rate l/h	Electro-welded pipes				Pipe without welding			
	1/2"		3/4"		1/2"		3/4"	
	Pressure drop Pa/m	Speed m/s	Pressure drop Pa/m	Speed m/s	Pressure drop Pa/m	Speed m/s	Pressure drop Pa/m	Speed m/s
200	41	0,21			70	0,25		
220	49	0,23			85	0,28		
240	57	0,25			100	0,31		
260	66	0,28			115	0,33		
280	75	0,30			129	0,36		
300	86	0,32			150	0,39		
320	96	0,34			165	0,41		
340	108	0,36	31	0,22	190	0,44	45	0,25
360	119	0,38	35	0,23	200	0,46	50	0,26
380	132	0,40	38	0,24	220	0,49	55	0,28
400	145	0,42	42	0,25	250	0,51	60	0,29
420	159	0,45	46	0,27	270	0,54	65	0,31
440	173	0,47	50	0,28	295	0,57	70	0,32
460	188	0,49	54	0,29	340	0,61	76	0,33
480	203	0,51	58	0,30	350	0,62	82	0,35
500	219	0,53	62	0,32	360	0,66	90	0,36
550	262	0,58	73	0,35	450	0,71	110	0,40
600	309	0,64	86	0,38	525	0,77	130	0,44
650			100	0,41			150	0,47
700			114	0,44			170	0,51
750			130	0,48			195	0,54
800			146	0,51			220	0,58
850			164	0,54			250	0,62
900			182	0,57			275	0,65
950			202	0,60			300	0,69
1000			222	0,64			350	0,75
1100			266	0,70			400	0,80
1200			313	0,76			455	0,88
1300			364	0,83			550	0,95
1400			420	0,88			640	1,04

For average water temperatures other than 75 °C, the values in Table 9 must be corrected, applying the coefficients shown in Table 10.

Tab.10 Coefficients for average water temperatures different from 75 °C

Temperature	40°C	60°C	90°C	120°C	140°C
Coefficient	1,18	1,06	0,96	0,91	0,87

2.15 Pressure drops of headers

Table 11 and 12 show the pressure drops in a pair of headers based on their water flow rate, the type of supply (same-side or opposite) and the diameter of the pipes ($\frac{1}{2}$ " or $\frac{3}{4}$ ").

Tab.11 Pressure drop in Pa of a PAIR OF HEADERS - PIPES $\frac{1}{2}$ "

Total flow rate of headers l/h	Pressure drop in pair of headers A Opposite sides number of pipes per panel									Pressure drops in pair of headers AA-B - Same side number of pipes per panel			
	2	3	4	5	6	7	8	9	10	4	6	8	10
400	110									240	140		
500	170	100								380	220		
600	240	150	100							540	310	210	
700	320	200	140	110						730	420	290	220
800	420	250	180	140	120	100				960	550	380	280
900	530	320	230	180	150	130	110			1210	690	480	360
1000	650	400	280	220	180	160	140	120	110	1500	850	580	440
1200	940	560	410	320	260	230	200	180	160	2150	1230	840	640
1400	1270	770	550	430	360	300	270	240	220	3000	1670	1150	870
1600	1660	1000	720	560	460	400	350	310	280		2200	1500	1150
1800	2100	1270	910	710	590	500	440	390	350		2800	1900	1450
2000		1560	1120	880	720	620	540	480	440		3400	2350	1800
2250		2000	1420	1100	910	800	680	610	550			3000	2300
2500			1750	1370	1130	980	840	750	680			3700	2800
2750			2100	1650	1360	1200	1050	910	830			4400	3400
3000				2000	1630	1400	1250	1080	980				4000
3500				2700	2200	1900	1650	1500	1350				5400
4000					2900	2500	2150	1950	1750				
4500						3200	2800	2500	2200				
5000						3900	3400	3000	2800				
5500							4100	3700	3300				
6000								4400	3900				
7000									5400				

Tab.12 Pressure drop in Pa of a PAIR OF HEADERS - PIPES $\frac{3}{4}$ "

Total flow rate of headers l/h	Pressure drops in pair of headers A - Opposite sides number of pipes per panel					Pressure drops in pair of headers AA-B - Same side number of pipes per panel			
	2	4	6	8	10	4	6	8	10
800						320			
900	180					400	240		
1000	220	100				500	290	210	
1200	320	150	100			710	420	300	230
1400	440	200	140	110		970	570	400	310
1600	570	260	180	140	120	1300	740	530	410
1800	720	330	230	180	150	1600	940	660	520
2000	890	410	280	220	190	2000	1200	840	640
2250	1150	520	350	280	240	2500	1500	1050	800
2500	1400	640	430	340	290	3100	1800	1300	1000
2750	1700	770	530	420	350	3800	2200	1550	1200
3000	2000	920	630	490	420	4500	2600	1850	1450
3500	2700	1300	850	670	570		3600	2500	1950
4000	3600	1650	1100	870	740		4700	3300	2550
4500		2100	1400	1100	940			4200	3200
5000		2600	1750	1400	1150			5100	4000
5500		3100	2100	1700	1400			6200	4800
6000			2500	2000	1700				5700
7000			3400	2700	2300				7800
8000			4450	3500	3000				
9000				4400	3800				
10000				5500	4600				
12000					6700				

2.16 Calculation of pressure drop of a panel

To determine the pressure drop of a radiant panel, you need to add the pressure drop of the pipes to that of the headers, calculated based on the data provided in paragraphs 2.14 and 2.15.

Here are a few examples.

First example

Consider a radiant panel model 8/100 with a length of 42 metres (Fig. 25) with electro-welded pipes of 1/2" and with opposite connections (type A headers).

Water delivery temperature $t_1 = 85^\circ\text{C}$
 Water return temperature $t_2 = 75^\circ\text{C}$
 Ambient temperature $t_a = 15^\circ\text{C}$

$$\Delta T = \frac{t_1 + t_2}{2} - t_a = t_m - t_a = 65^\circ\text{C}$$

With this data, Table 3 shows that the thermal emission per metre of the panel is:

$$\Phi_m = 628 \text{ W/m}$$

The total thermal power of the panel with a length of 42 metres is therefore:

$$\Phi_p = 628 \text{ W/m} \times 42 \text{ m} = 26'376 \text{ W}$$

and its water flow rate:

$$Q_p = \frac{\Phi_p \times 0,86}{t_1 - t_2} = \frac{26'376 \times 0,86}{10} = 2'268 \text{ kg/h}$$

Since the panel has 8 pipes and opposite connections, the inlet water is equally divided among all 8 pipes, and so the water flow rate of each pipe is:

$$Q_i = \frac{Q_p}{8} = \frac{2'268}{8} = 283 \text{ kg/h} \approx 283 \text{ l/h}$$

upper value at suggested minimum flow rate in a pipe of 1/2" (220 l/h).

Table 9 shows that the pressure drop in the pipes is roughly 76 Pa/m.

Therefore, the total pressure drop in the pipes is:

$$\Delta p_i = 42 \text{ m} \times 76 \text{ Pa/m} = 3'192 \text{ Pa}$$

In Table 11, under the total flow rate of the panel, which is about 2,268 l/h, one finds that the pressure drop in the pair of headers Δp_c is 693 Pa.

The pressure drop of the panel will be the sum of the two values, therefore:

$$\Delta p_p = \Delta p_i + \Delta p_c = 3'192 + 693 = 3'885 \text{ Pa}$$

(equal to 0.39 m c. a.)

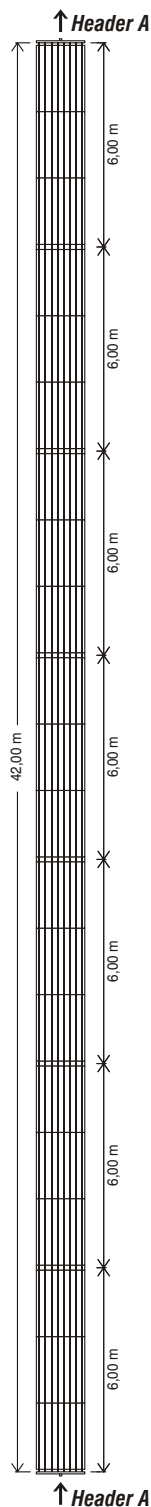

Fig.25

Second example

Consider a radiant panel model 10/100 with a length of 42 metre (Fig. 26) with electro-welded pipes of 1/2" and with same-side connections (type AA and B headers).

Water delivery temperature $t_1 = 85^\circ\text{C}$
 Water return temperature $t_2 = 75^\circ\text{C}$
 Ambient temperature $t_a = 15^\circ\text{C}$

$$\Delta T = \frac{t_1 + t_2}{2} - t_a = t_m - t_a = 65^\circ\text{C}$$

With this data, Table 3 shows that the thermal emission per metre of the panel is:

$$\Phi_m = 751 \text{ W/m}$$

The total thermal power of the panel with a length of 42 metres is therefore:

$$\Phi_p = 751 \text{ W/m} \times 42 \text{ m} = 31'542 \text{ W}$$

and its water flow rate:

$$Q_p = \frac{\Phi_p \times 0,86}{t_1 - t_2} = \frac{31'542 \times 0,86}{10} = 2'713 \text{ kg/h}$$

Since the AA header has a diaphragm in it, the inlet water is divided among 5 pipes. Therefore, the flow rate of each pipe is:

$$Q_i = \frac{Q_p}{5} = \frac{2'713}{5} = 543 \text{ kg/h} \approx 543 \text{ l/h}$$

upper value at suggested minimum flow rate in a pipe of 1/2" (220 l/h).

Table 9 shows that the pressure drop in the pipes is roughly 256 Pa/m.

Therefore, the total pressure drop in the pipes is:

$$\Delta p_i = 42 \text{ m} \times 2 \times 256 \text{ Pa/m} = 21'504 \text{ Pa}$$

In Table 11, under the total flow rate of the panel, which is about 2'713 l/h, one finds that the pressure drop in the pair of headers Δp_c is about 3,320 Pa.

The pressure drop of the panel will be the sum of the two values, therefore:

$$\Delta p_p = \Delta p_i + \Delta p_c = 21'504 + 3'320 = 24'824 \text{ Pa}$$

(equal to 2.53 m c. a.)

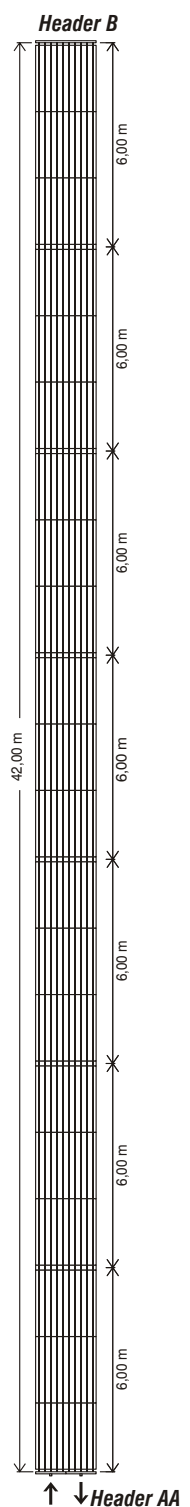

Fig.26

Third example

Consider a radiant panel model 10/100 with a length of 84 metres (Fig.27) with electro-welded pipes of 3/4" and with same-side connections (type AA and B headers).

Water delivery temperature $t_1 = 85^\circ\text{C}$
 Water return temperature $t_2 = 70^\circ\text{C}$
 Ambient temperature $t_a = 15^\circ\text{C}$

$$\Delta T = \frac{t_1 + t_2}{2} - t_a = t_m - t_a = 62,5^\circ\text{C}$$

With this data, table 4 shows that the thermal emission per metre of the panel is:

$$\Phi_m = 756 \text{ W/m}$$

The total thermal power of the panel with a length of 84 metres is therefore:

$$\Phi_p = 756 \text{ W/m} \times 84 \text{ m} = 63'504 \text{ W}$$

and its water flow rate:

$$Q_p = \frac{\Phi_p \times 0,86}{t_1 - t_2} = \frac{63'504 \times 0,86}{15} = 3'640 \text{ kg/h}$$

Since the AA header has a diaphragm in it, the inlet water is divided among 5 pipes. Therefore, the flow rate of each pipe is:

$$Q_i = \frac{Q_p}{5} = \frac{3'640}{5} = 728 \text{ kg/h} \approx 728 \text{ l/h}$$

Upper value at suggested minimum flow rate in a pipe of 3/4" (500 l/h).

Table 9 shows that the pressure drop in the pipes is 123 Pa/m.

Therefore, the total pressure drop in the pipes is:

$$\Delta p_i = 84 \text{ m} \times 2 \times 123 \text{ Pa/m} = 20'664 \text{ Pa}$$

In table 12, under the total flow rate of the panel, which is about 3'640 l/h, one finds that the pressure drop in the pair of headers Δp_c is about 2,120 Pa.

The pressure drop of the panel will be the sum of the two values, therefore:

$$\Delta p_p = \Delta p_i + \Delta p_c = 20'664 + 2'120 = 22'784 \text{ Pa} \text{ (equal to 2.32 m c.a.)}$$

2.17 Static pressure and flow rate of the electric pump

In a circuit of radiant panels, the flow rate of the electric pump is determined from the sum of the flow rates of the single panels of the circuit. Its static pressure is obtained by adding the pressure drops of the least favoured radiant panel, any cut-off and calibration valves on the connection of that panel, the pipes that supply it and the heating plant.

Consider, for example, the need to heat a warehouse measuring 90x60 metres, with a height of 9 metres, and with the panels installed at a height of 8 metres.

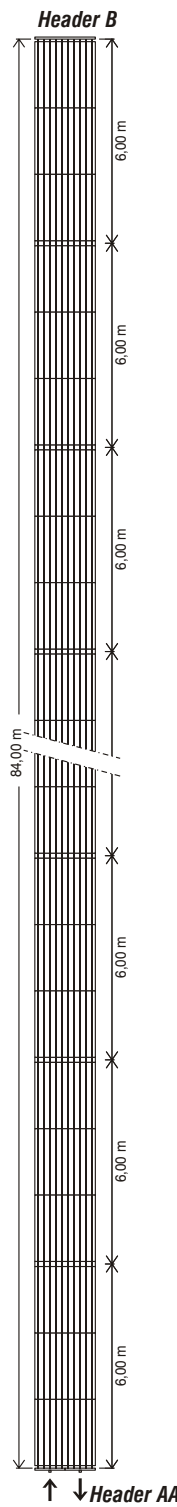

Fig.27

1st solution

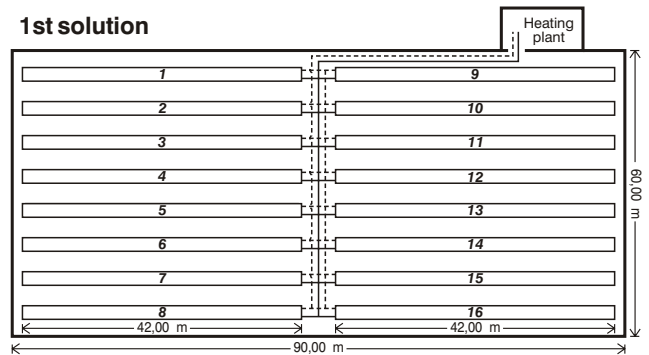

Fig.28

16 panels model 10/100-1/2" with a length of 42 metres are to be provided.

Considering as valid the conditions described in the second example of the previous paragraph, a panel 10/100-1/2" with a length of 42 metres has a pressure drop of about 2.53 m c.a. and a flow rate of 2,713 l/h. The least favoured panel will be number 8 (or number 16).

2nd solution

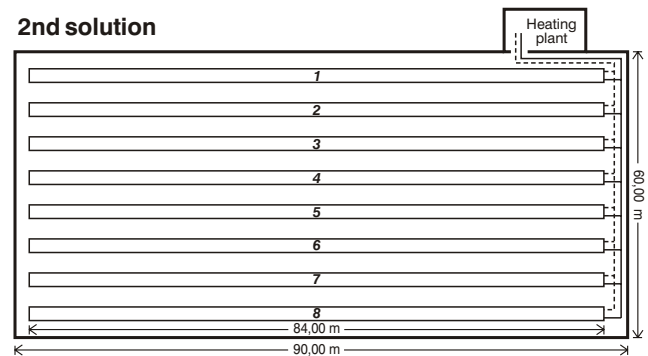

Fig.29

8 panels model 10/100-3/4" with a length of 84 metres are to be provided.

Considering as valid the conditions described in the third example of the previous paragraph, a panel 10/100-3/4" with a length of 84 metres has a pressure drop of about 2.32 m c.a. and a flow rate of 3,640 l/h. The least favoured panel will be number 8.

Obviously, the second solution is more rational and advantageous, for the following reasons:

- since the number of connections is limited, there is no need for "inverse return". For balancing of the circuit, it is possible to use a few calibration valves.
- The use of panels with pipes of 3/4" allows for the creation of rather long panels with modest pressure drops.

In the case in question, the 3/4" panel has a greater emission than the 1/2" panel. Therefore, with the same installed power (about 500 kw) a greater temperature difference can be used (85 °C-70 °C instead of 85 °C-75 °C). This will provide a flow rate of 29 m³/h as opposed to the 43 m³/h required by panels with pipes of 1/2".

Therefore, with the same installed power and pressure drops, there is reduced flow rate, which translates into smaller pipe diameters and reduced power of the electric pump.

All this leads to a reduction in the amount of pipes required for distribution, resulting in substantial savings.

2.18 Adjustment

Since this is a system with low thermal inertia, the ambient temperature can be controlled in a variety of ways, depending on the type and importance of the system. However, you should keep mind that with ceiling mounted radiant panel systems, changes should be in the temperature of the water delivered to the panels. The flow rate should be kept constant. "Turning the panels on and off" may create unpleasant sensations (like moving from the sunshine into shade). This is because blocking circulation means blocking the beneficial effect of radiance.

It is therefore advisable to use a mixer valve, regulator and ambient probes as shown in *diagram 1*. The mixer valve "prepares" the water to be sent to the panels so as to maintain the desired ambient temperature.

Normal ambient probes can be installed to measure the air temperature. Today the market also includes probes that directly measure the operating temperature.

Since the system quickly comes up to operating power, to reduce operating costs it is advisable to provide a programmable timer for daily and weekly shutdowns. In this case it is advisable to include an anti-freeze function.

In panel systems of a certain size (warehouses of over 10,000 m²) in which operating costs are substantial, control should be complete with an external probe. However, this probe must never limit the operation of the ambient probe (*diagram 2*).

For large-scale industrial complexes, again for economical management, it is necessary to make use of controlled, programme adjustment (*diagram 3*).

Diagram 1

Adjustment of delivery hot water temperature based on ambient temperature, timer and anti-freeze function for start-up if the ambient temperature drops below a certain value during shutdown.

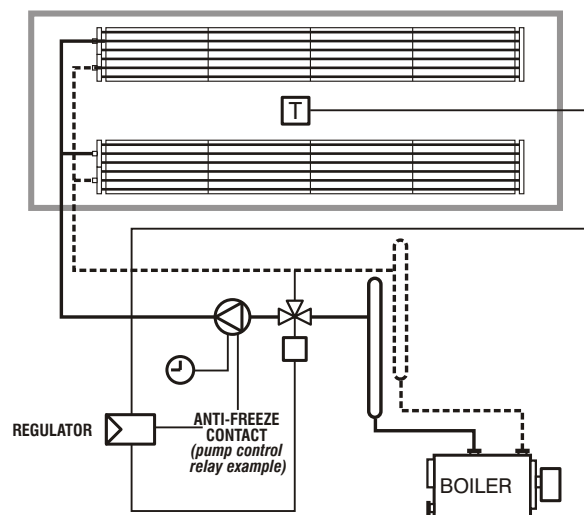

Fig. 30

Diagram 2

Adjustment of delivery hot water temperature based on external temperature with correction made by ambient, programmable timer for weekly or night-time shutdown with anti-freeze function to be activated should the ambient temperature, during shutdown, drop below a certain value (anti-freeze contact wiring parallel to the system on/off control contact)

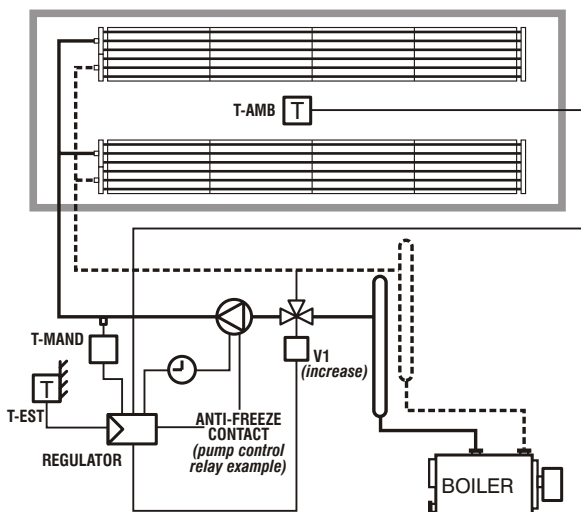

Fig. 31

Diagram 3

Adjustment for systems with variation of the programmed pre-heating hours based on the external temperature, to ensure in any condition the desired ambient temperature with night-time and holiday shutdowns. Adjustment and control of the temperature difference of the water and of the operating temperature.

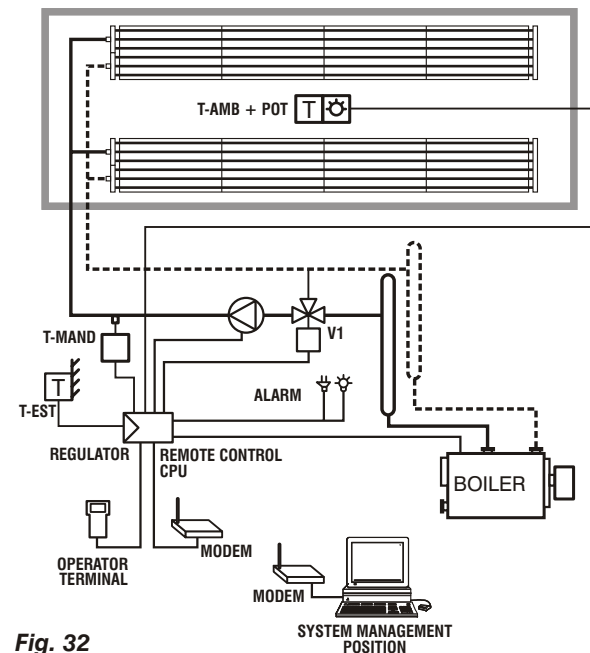

Fig. 32

If the system includes a series of rooms all with the same characteristics, it is possible to use a single mixer valve with various ambient probes.

If instead it is necessary to heat rooms that are not uniform, it will be necessary to provide several independently controlled circuits.

2.19 Methods of installation and dilation

After installing the suspension ties on the roof, the panels are to be raised in order to hook the ties onto the brackets on the panels.

The brackets for fastening are arranged on the panels about 95 cm from one another (see Fig. 2). Normally, one is hooked on every two metres. Examples follow of the distance between suspension points, creating only modules of 6 metres (Fig. 33) and modules of 6 and 4 metres (Fig. 34).

It is indispensable that the fastening system that is used allows adjustment in height of the ties to allow perfectly straight installation without bends.

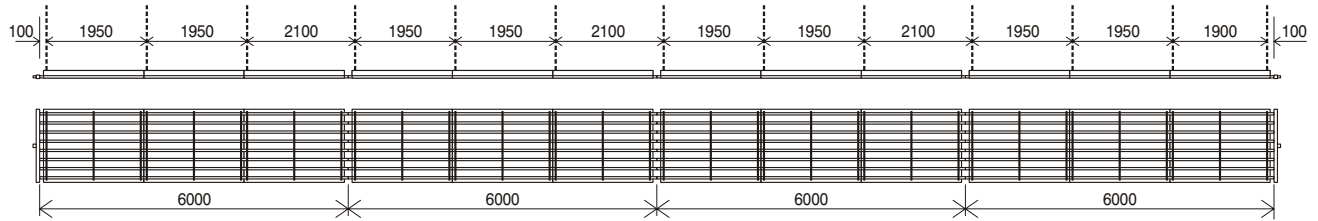

Fig.33 Example of distance between suspension points with modules of 6 metres

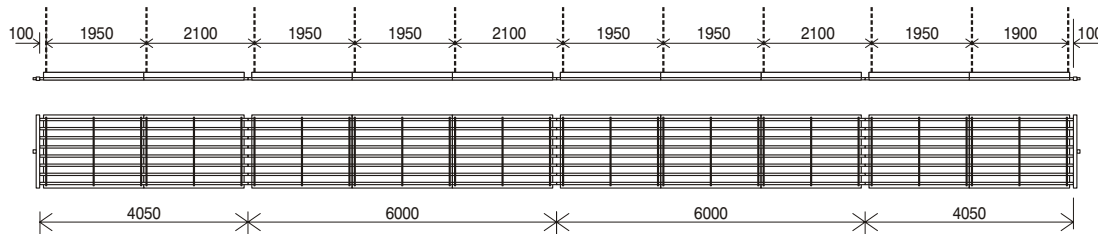

Fig.34 Example of distance between suspension points with modules of 4 and 6 metres

During operation, radiant panels behave like all pipes that have hot fluids passing through them. This means they undergo varying degrees of dilation depending on their length and the temperature of the fluid.

It is important for the ties to be long enough that they do not keep the panels from dilating (Fig. 35 and Table 13).

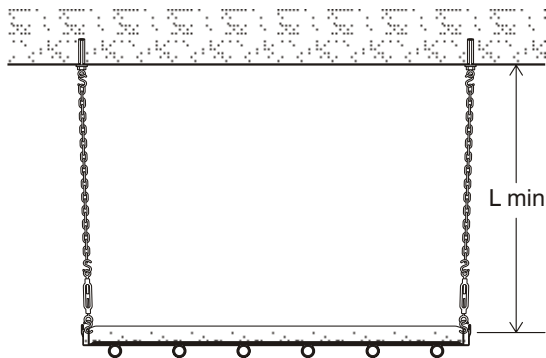

Fig.35 Minimum length of suspension ties

Table 13 shows the minimum length of the ties based on the length of the panel and the difference between the average temperature of the heating fluid and the ambient temperature.

Tab.13 Minimum length of suspension ties (mm)

Length of panels (m)	Temperature difference ($T_m - T_a$)				
	75 °C	100 °C	125 °C	150 °C	175 °C
25	150	200	250	300	350
50	300	400	450	550	650
75	450	550	700	850	1000
100	550	750	950	1100	1300
150	850	1100	1400	1650	1950
200	1100	1500	1900	2200	2600

If ties of a sufficient length cannot be provided, it will be necessary to provide rigid supports with sliding rollers (Fig. 36).

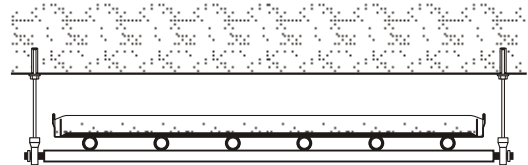

Fig.36 Example of brackets with rollers

To keep from placing too much stress on the radiant panels, the connection pipes between the headers and the distribution network must be shaped so that they absorb the dilation that takes place in the system.

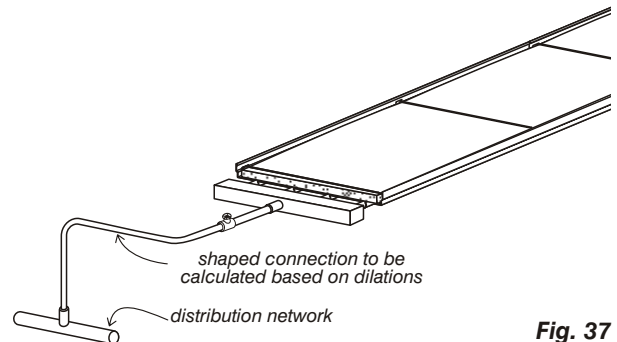

Fig. 37

To make air venting easier, the headers include threaded inserts of 3/8" for the installation of automatic vent valves.

2.20 Examples of systems of fastening to roof

The following drawings show some examples of suspension systems of the radiant panels.

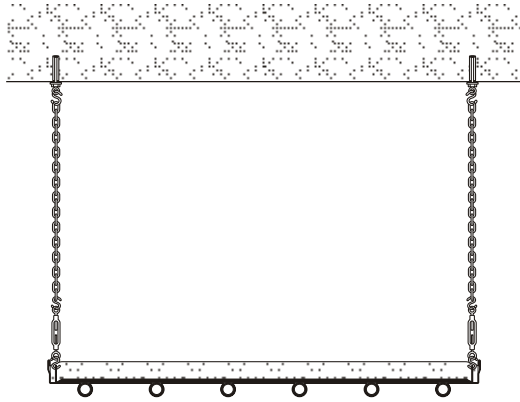

Fig.38 Example of brackets with chains

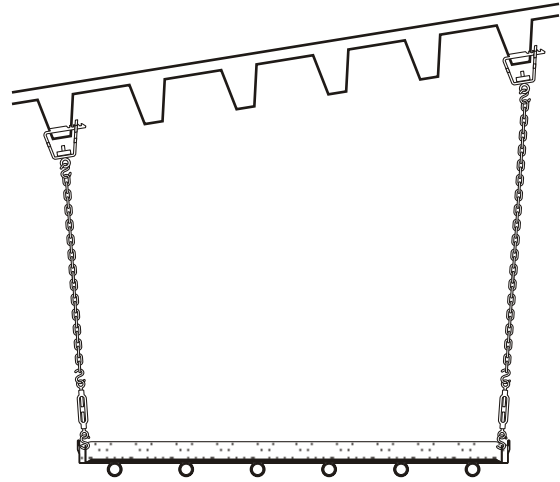

Fig.41 Example of brackets on sheet metal with frets

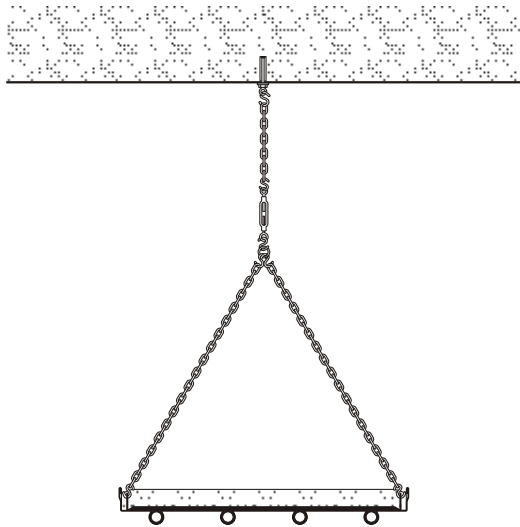

Fig.39 Example of brackets with chains

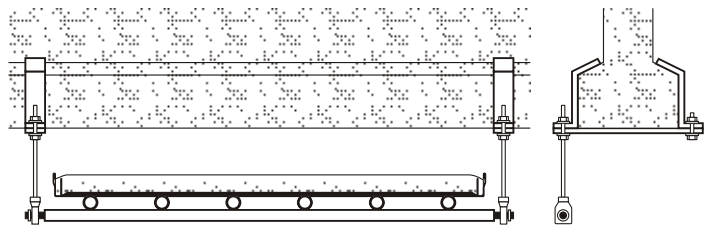

Fig.42 Example of brackets with roller for panels transversal to roof tiles

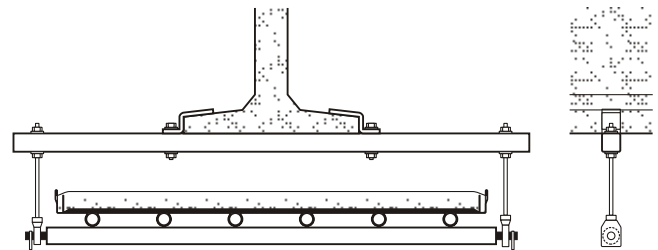

Fig.43 Example of brackets with roller for panels parallel to roof tiles

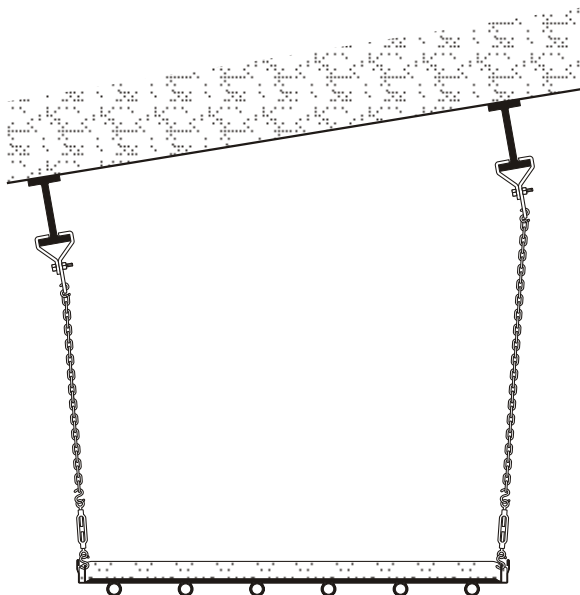

Fig.40 Example of brackets hooked onto metal beams

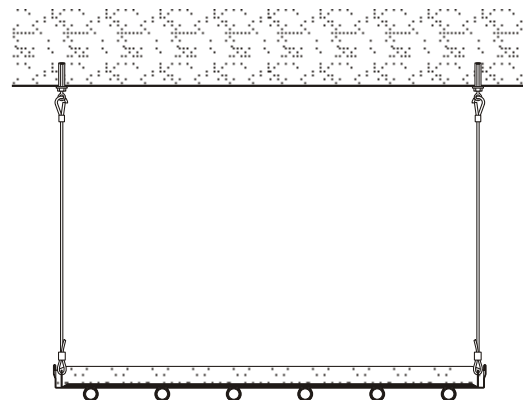

Fig.44 Example of brackets with steel ties

2.21 Packaging

The panels are normally shipped stacked on packs of about 10 pieces, strapped and placed on suitable wood spacer pallets.

Protective strips of polyethylene are placed between the panels near the brackets.

Special packaging on request.

2.22 Assembly

If the panels are to be ceiling-mounted in buildings with a height of over four metres, the safest and most economical way of doing this is to use elevator platforms with a lifting capacity of over 400 kg and that can reach the highest parts of the building.

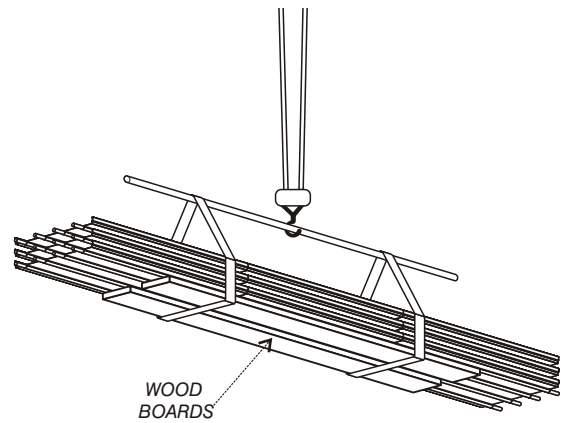

These machines can be rented nationwide.

Start by securing the suspension ties to the roof. Tie rods are not included in the supply. They may consist of chains, steel cables, threaded bars or other devices.

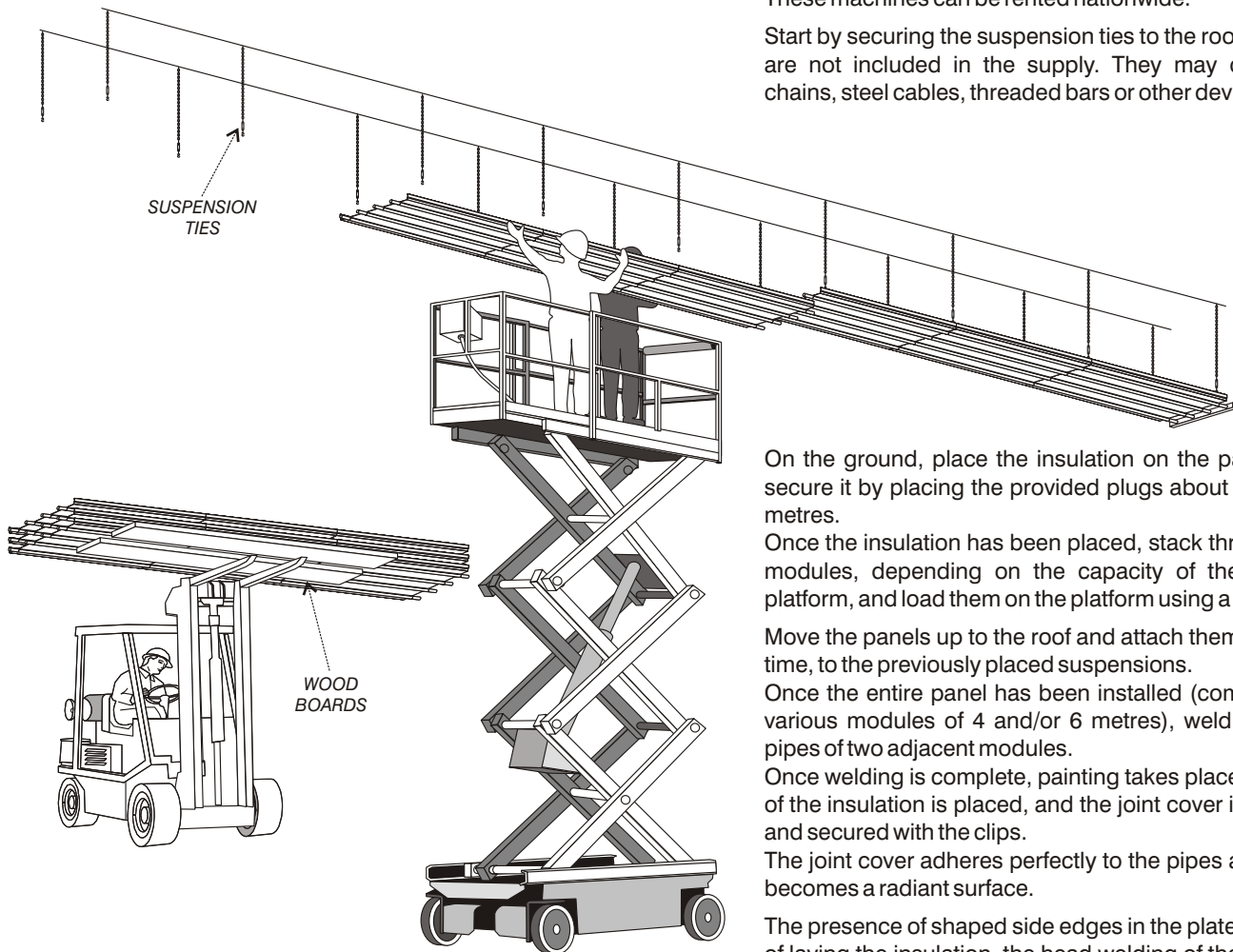

On the ground, place the insulation on the panels and secure it by placing the provided plugs about every two metres.

Once the insulation has been placed, stack three or four modules, depending on the capacity of the elevator platform, and load them on the platform using a forklift.

Move the panels up to the roof and attach them, one at a time, to the previously placed suspensions.

Once the entire panel has been installed (composed of various modules of 4 and/or 6 metres), weld the head pipes of two adjacent modules.

Once welding is complete, painting takes place. The rest of the insulation is placed, and the joint cover is inserted and secured with the clips.

The joint cover adheres perfectly to the pipes and it also becomes a radiant surface.

The presence of shaped side edges in the plate, the ease of laying the insulation, the head welding of the perfectly aligned pipes, and the simplicity of inserting the joint cover all reduce and simplify assembly times and hence installation costs.

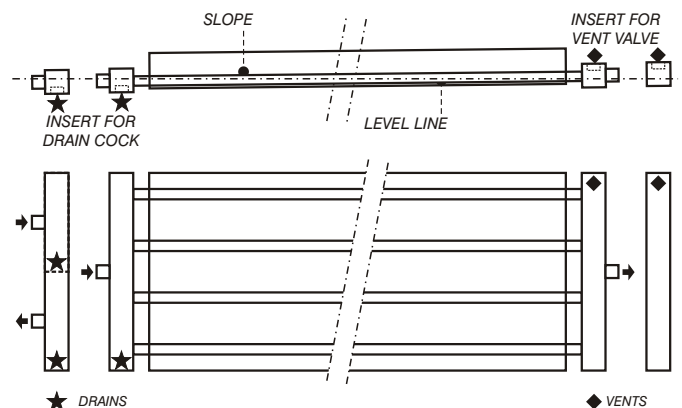

Laying and securing the insulating mat

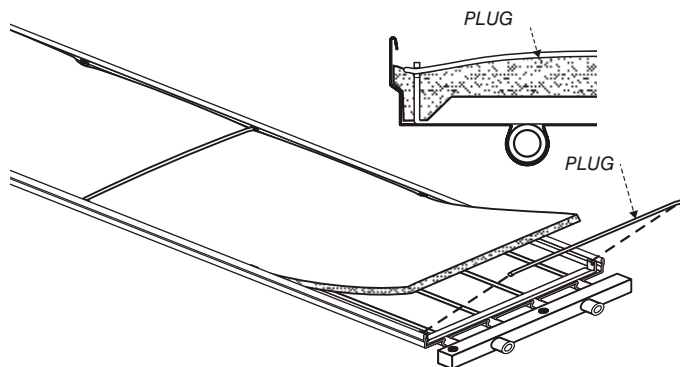

Welding of modules

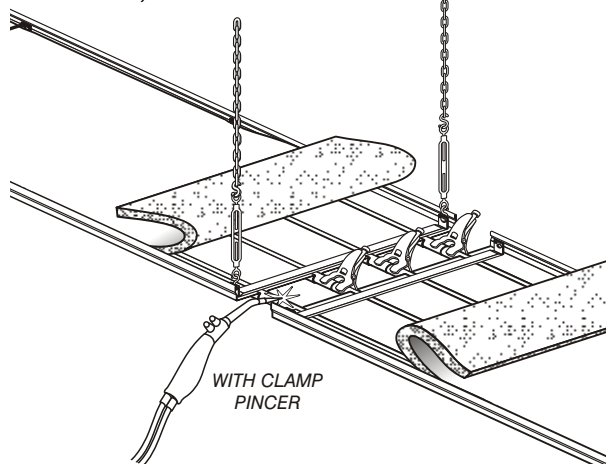
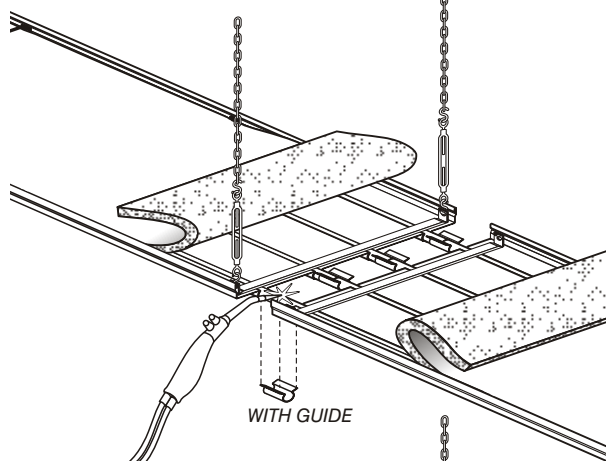

Installation of joint cover

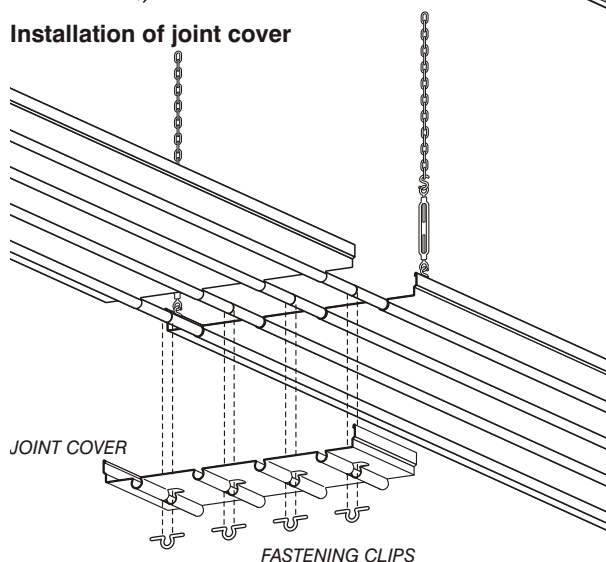

2.23 Conclusions

Currently in Europe, there is not a single method for calculating the heat loss of a building. Nor is there a specific standard for the calculation of radiance systems with ceiling mounted radiant panels.

For over 20 years, the ECOPAN technical department has used a method of calculation which is based on the temperature of the inner surfaces of the room and their interaction with the radiant panels.

The basis of the calculation is the operating temperature, which depends on the air temperature, the temperature of the walls, the temperature and surface of the panels and air circulation.

A complete study is quite complex and requires consideration of a number of factors.

Thousands of ECOPAN systems have confirmed the validity of the calculations.

A rough estimate of the thermal requirements of a room to be heated with radiant panels can be obtained using the following formula:

$$\Phi = [(S_1 \times K_1 \times \Delta T_1) + (S_2 \times K_2 \times \Delta T_2) + (S_3 \times K_3 \times \Delta T_3) + (S_4 \times K_4 \times \Delta T_4) + \dots + (V \times R \times c_p \times \rho \times \Delta T_E)]$$

where:

Φ = total thermal requirement (W)

S_i = dispersing surfaces such as external walls, ceiling, floor, internal walls, etc. (m²)

K_i = transmittance of surfaces (W/m² K)

$\Delta T_i = t_o - t_i$ where t_i is the temperature of the air outside the room and t_o is the temperature of the room that one wishes to obtain (K)

V = volume of room (m³)

R = air/hour exchanges expected (1/h)

ρ = air density (kg/m³)

c_p = specific heat of air (Wh/kg K)

ΔT_E = difference between ambient temperature and external temperature (K)

With design winter external temperatures of -5°C , requested operating temperature of $+16^\circ\text{C}$ and air exchange of 0.3 volumes/h, approximately, for a newly constructed warehouse, it is possible to estimate a need of 1 m² of panels for each 7 ÷ 8 m² of floor space.

Besides attaining comfort, the client is also interested in system costs and operating efficiency. Proper sizing helps reduce these costs.

With the ambient values listed above, purely as a guideline, based on measurements made, one can estimate annual operating costs of about 1.50 ÷ 1.85 €/m² of warehouse space. The larger the warehouse, the less the operating cost.

ECOPAN has been producing and selling radiant panels for ceiling installation for over twenty years.

This experience has shown that the use of this product is the best solution for heating large industrial and civil locations.

Radiant panels fully satisfy the needs for silent operation and lack of air movement. It evenly heats rooms with reduced energy consumption and no fire hazard.

3 ACCESSORIES

Anti-convections side skirts

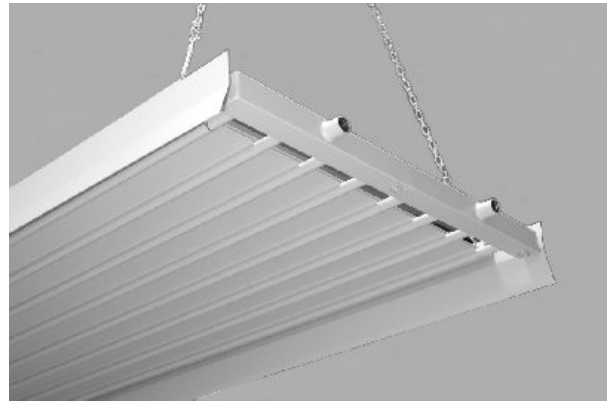
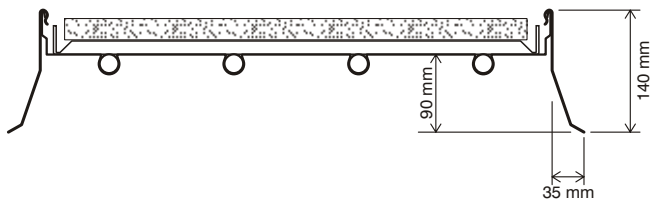

Concealed side profiles for suspensions at variable intervals

They allow suspension ties to be attached anywhere on the panel. These profiles, anchored directly on the brackets, stiffen the panel so that the space between one anchor and the next can be increased. They remain completely concealed.

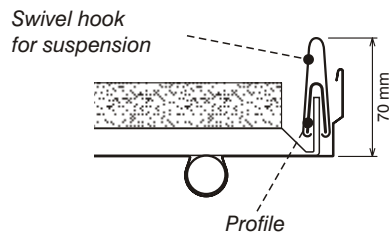

Joint covers for pipe joints with sleeves for press fitting

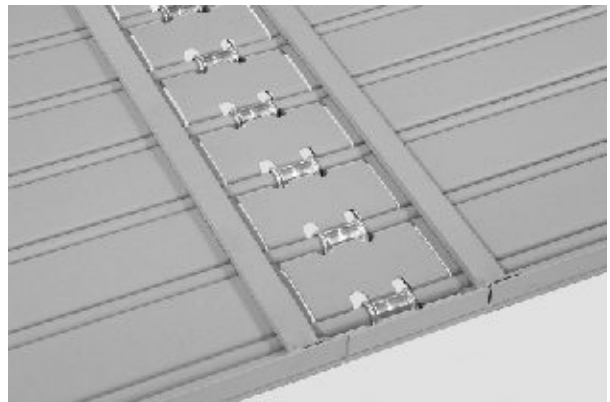
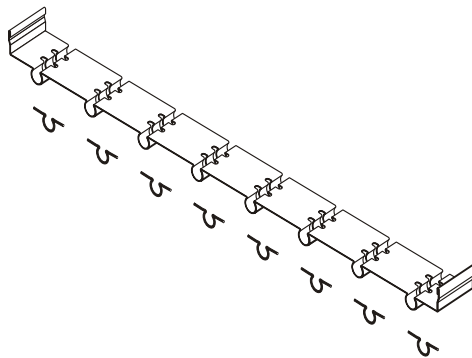

Headers for assembly with press fitting

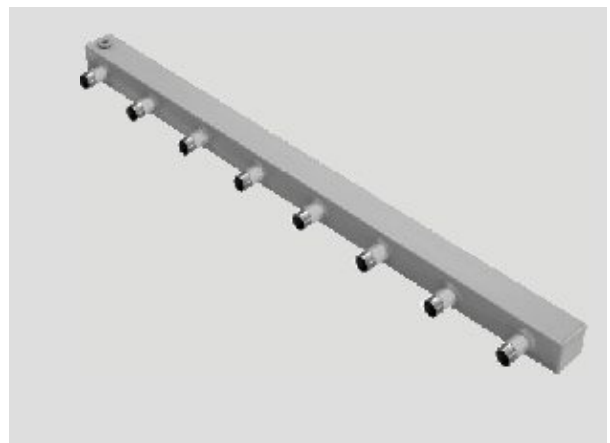

Insulation covers for heads of panels

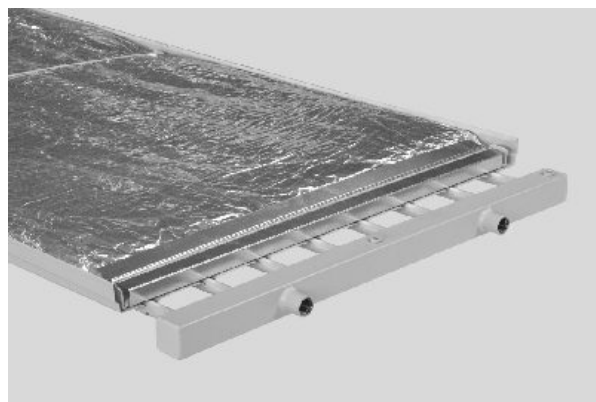
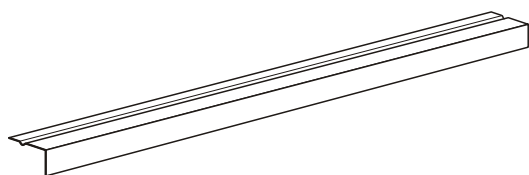

Upper sheet metal protections for gymnasiums

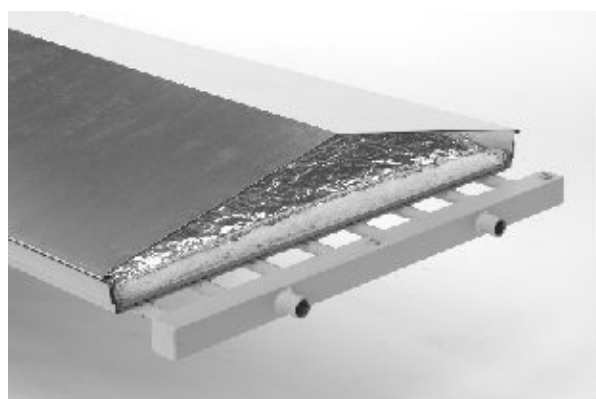
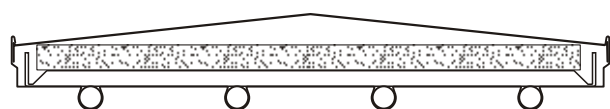

Panels with pipes of 1/2", interval 111 mm with room for lamps

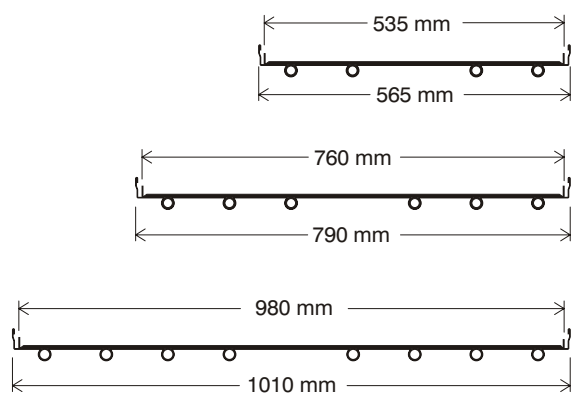

4 CERTIFICATIONS

4.1 ECOPAN radiant panel

Model	Number of test report as per European standard EN 14037-1,-2,-3	Nominal thermal emission $\Delta T = 55 \text{ K}$ Φ (*) W/m	Characteristic equation exponent n (*)	Characteristic equation constant K (*) W/K ⁿ
2/150 1/2"	DC203D12.1821	180	1,1752	1,6220
3/150 1/2"	DC203D12.1821 / 1824	244	1,1708	2,2415
4/150 1/2"	DC203D12.1824	309	1,1663	2,8830
5/150 1/2"	DC203D12.1824 / 1827	370	1,1670	3,4450
6/150 1/2"	DC203D12.1824 / 1827	431	1,1677	4,0040
7/150 1/2"	DC203D12.1824 / 1827	492	1,1684	4,5598
8/150 1/2"	DC203D12.1827	554	1,1691	5,1127
2/150 3/4"	DC203D12.1820	190	1,1760	1,7056
4/150 3/4"	DC203D12.1823	318	1,1763	2,8516
6/150 3/4"	DC203D12.1823 / 1822	449	1,1773	4,0143
8/150 3/4"	DC203D12.1822	581	1,1783	5,1687
4/100 1/2"	DC203D12.1819	278	1,1828	2,4278
5/100 1/2"	DC203D12.1819 / DC204D12.1977	347	1,1806	3,0599
6/100 1/2"	DC204D12.1977	413	1,1784	3,6753
7/100 1/2"	DC204D12.1977 / 1950	466	1,1802	4,1120
8/100 1/2"	DC204D12.1977 / 1950	516	1,1820	4,5234
9/100 1/2"	DC204D12.1977 / 1950	566	1,1837	4,9290
10/100 1/2"	DC204D12.1950	616	1,1855	5,3288
4/100 3/4"	DC204D12.1989	279	1,1843	2,4274
6/100 3/4"	DC204D12.1985	415	1,1793	3,6744
8/100 3/4"	DC204D12.1985 / 1949	534	1,1825	4,6691
10/100 3/4"	DC204D12.1949	650	1,1857	5,6154

(*) Nominal thermal emission as per EN 14037, based on tests carried out at the HLK laboratory at the University of Stuttgart.

This emission, relative to $\Delta T = 55 \text{ K}$ is obtained from the equation:

$$\Phi = K \cdot \Delta T^n$$

in which

Φ = thermal emission

K = characteristic equation constant

ΔT = difference between the average temperature of the fluid and the ambient temperature

n = characteristic exponent equation

4.2 Insulating panel

Fibreglass wool treated with thermosetting resin, covered on the upper side with aluminium foil.

Its properties include:

- chemical inertia, immune to attack by parasites and rodents, does not decay or absorb humidity, resistant to even substantial temperature changes.

The completely inorganic nature of fibreglass wool ensures its long-lasting performance.

Fire reaction

Class A1 according to test methods in standard EN 13501-1.

Thickness	40 mm
Thermal conductivity at an average temperature of 40°C	0,048 W/mK
Density	14 kg/m ³ ± 10%
Thermal resistance	0.83 m ² K/W

5 TECHNICAL SPECIFICATIONS

Panels with pipes electro-welded

Ceiling mounted radiant panels with emission certified as per harmonized European standard EN 14037, composed of:

Plate in quality steel sheet metal, cold worked using mechanical stamping and drawing process, to obtain deep grooves that wrap 2/3 of the outer surface of the pipe so as to obtain maximum downward radiance.

Wide range of models based on the number of pipes they are made of, 7 models with interval of 111 mm and 7 with an interval of 150 mm, all available with pipes of 1/2" or of 3/4".

Length of 4 or 6 metres obtained by assembling sheets of 2 metres so as to prevent them from deforming and to contain sliding between pipes and sheet metal within limits of elasticity.

Electro-welded steel **pipes** with a thickness of 1.5 mm made from laminated strip, diameter 1/2" (or 3/4"), electronically tested at the steelworks and certified, suitable for liquids at a temperature of up to 120°C and operating pressures of up to 6 bar.

Steel **pipes** with no welding (or with equivalent characteristics) with a diameter of 1/2" (or 3/4"), suitable for liquids at a temperature of up to 180°C and operating pressures of up to 16 bar.

Anchoring brackets located about one every metre to stiffen the structure, composed of rectangular tube that is especially flat so as to allow continuity and adherence of the insulation to the sheet metal, thus reducing thermal points.

Side edges with special profile obtained from the plate, thus extending the radiant surface. They contain and hide the insulating mat.

Head **headers** welded to pipes and tested in the factory for the required pressures.

Fibreglass wool **mat** with a thickness of 40 mm, density 14 kg/m³, covered on the upper face with aluminium foil, fire reaction class A1 as per standard EN 13501-1.

Joint covers to be placed on joints between modules, with the same profile as the main sheet metal, to be pressed in and secured from underneath with clips.

Painting carried out after washing, degreasing, and phosphating by immersion in tub containing water-soluble enamel with non-toxic epoxy powder resins, followed by kiln baking. The standard colour is RAL 7032 silicon grey; other RAL colours are available on request.

This paint resists up to 170°C in systems supplied with water and 140°C in steam systems. For uses at higher temperatures, there are specially suited paints.

ECOPAN srl
via Mameli, 44
32100 Belluno (Italy)
tel. +39 0437 32005
fax +39 0437 31027
e.mail: info@ecopan.net
www.ecopan.net



ECOPAN®



MAN. TEC. EN 03-07
Rights to modification reserved

ECOPAN® is a registered trademark. - ECOPAN® modular radiant panels are patented. - The technical, constructional and dimensional data are not binding and may be modified with no advance notice. This manual may not be reproduced, wholly or in part, without written authorization in advance from Ecopan S.r.l.